



**VTC-IRE40/3516**  
**Day/Night Infrared 700 TV Line**  
**Bullet Camera w/150' Range**



- 700TVL High Resolution
- High Density 1/3" Sony EXVIEW CCD & Effio-E DSP
- 40 Infrared LEDs at 840nm enable viewing in total darkness up to 150 feet
- 0.003 Lux (F1.2 @ 40IRE) / 0 Lux with IR LEDs On
- E-WDR by Adaptive Tone Reproduction
- 3.5-16mm Varifocal Auto Iris Lens with External Adjustments for Focus and Zoom
- 2DNR Noise Reduction
- True Day/Night by ICR - Infrared Cut Removal
- Motion Detection
- Weatherproof IP68 NEMA Rating
- Privacy & Highlight Masking
- OSD (On Screen Display) and Secondary Video Output
- 24VAC/12VDC Dual Voltage

VITEK

1. Safety Instructions and Notes..... 2  
2. General Descriptions..... 3  
3. Supplied Items..... 4  
4. Part names..... 4  
5. Installation Instructions..... 5  
6. Setup Menu ..... 7  
7. Specifications ..... 20  
8. Dimensional Drawings ..... 21

## WARNING

To prevent fire or shock hazard, do not expose the unit to rain or moisture.



This symbol is intended to alert the user to the presence of important operating and maintenance (servicing) instructions in the literature accompanying the unit.



This symbol is intended to alert the user to the presence of uninsulated "dangerous voltage" within the product's enclosure that may be of sufficient magnitude to constitute a risk of electric shock.



### Caution

**To prevent electric shocks and risk of fire hazards, do NOT use other than specified power source.**

Warning (NTSC version) -- This equipment has been tested and found to comply with the limits for a Class A digital device, pursuant to part 15 of the FCC Rules. These limits are designed to provide reasonable protection against harmful interference when the equipment is operated in a commercial environment. This equipment generates, uses, and can radiate radio frequency energy and, if not installed and used in accordance with the instruction manual, may cause harmful interference to radio communications. Operation of this equipment in a residential area is likely to cause harmful interference in which case the user will be required to correct the interference at their own expense.

Caution -- Any changes or modifications in construction of this device that are not approved by the party responsible for compliance could void the user's authority to operate the equipment.

**Notice -- The images used in this manual are processed to help comprehension and may differ from the actual video of the camera.**

## 1. Safety Instructions and Notes

- Please read these safety and operating instructions before placing the camera into operation.
- Keep the manual in a safe place for later reference.
- Pay attention to safety when laying the connection cable and observe that the cable is not subjected to heavy loads, kinks, damage or moisture.
- Never open the device to expose boards or lenses.
- The warranty becomes void if repairs are undertaken by unauthorized persons.
- Only authorized service centers may perform maintenance or repairs.

- Use only a mild detergent to clean the housing.
- Keep the window surface clean of dirt or dust, which may reflect infrared light into the lens at night.
- The camera should never be operated beyond the technical specifications. This can lead to destruction.

## 2. General Descriptions

This camera is an ultra clear resolution camera that realizes over 700TVL resolution and a crisp color reproduction with Sony 960H EX-view CCD and Effio-E image signal processor.

Effio-E digital imaging system:

- Delivers crystal clear images with over 700TVL resolution that accurately captures every aspect of any scene
- Color signal processing provides optimum balance between luminance and chroma signals for high color reproducibility, even for a detailed scene containing very high spatial frequency
- Incorporates 2-D noise reduction signal processing

ICR mechanism:

- Enhances sensitivity up to 10x at night.
- Accepts infrared light

24VAC/12VDC dual power design:

- Offers flexibility of installation
- Ensures reliability

Main features:

- External adjustment controls for lens and On Screen Display (OSD)
- High Density 1/3" Sony EX-view CCD (960H)
- Resolution 700 Horizontal Lines
- 3.5-16mm Variable Focal Length Lens
- Weatherproof IP68 NEMA Rating Optimized for Outdoor Use
- Secondary Video Output for simple installation & Maintenance
- 40ea Self Adjusting "Dynamic Intensity" IR LEDs
- 150' Night Observation Range
- E-WDR by ATR (Adaptive Tone Reproduction)
- 2-D noise reduction
- True Day/Night with Automatically Removable IR Cut Filter (ICR)
- Motion Detection
- Privacy Mask Function
- OSD menu and camera ID
- Switches to B/W enabling infrared spectrum response in night mode
- Very low noise and superior picture quality
- Sensitivity of 0.003Lux (F1.2@40IRE)
- Automatic White Balance (ATW)
- Supply voltage: 24Vac/12Vdc Dual voltage

### 3. Supplied Items

- 1x VTC-IRE40/3516 Long range Weatherproof IR Bullet camera
- 1x Installation and Operating Instructions
- 1x Mounting template
- 1x ⑧ Sunshield with □ Attachment thumb screw for Sunshield panel
- 1x ① 3mm Hex L-wrench
- 4x ② anchors
- 4x ③ Wall mounting screws
- 1x ④ Video Sub-output cable

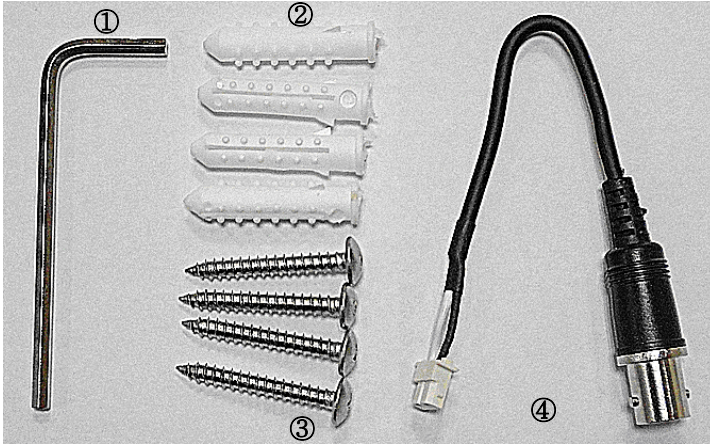

### 4. Part Names

#### 4.1 Front view

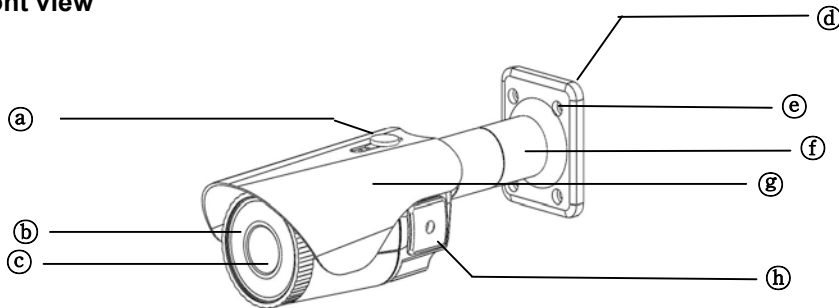

- Sunshield attachment thumb screw
- IR LED Panel
- Double Glass Window

- Mounting Bracket Foot
- ⓔ Foot mount Hole(x4)
- ⓕ Arm assembly

- ⓖ Sunshield
- ⓓ OSD (On Screen Display Control) cover

## 4.2 Rear side view

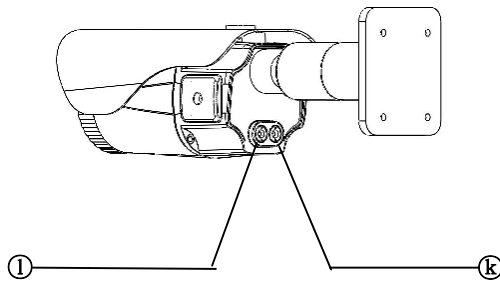

- ① Focus adjustment
- ② Zoom adjustment

## 5. Installation Instructions

- Make sure the power is not applied before the installation.
- Once the camera is installed, you may first connect the low voltage (AC24V or DC12V) wire to the camera power connector, then plug the AC adapter to the AC outlets to avoid an improper reset from power jitter and possible damage from voltage surge.

### 5.1. Mounting the camera

- 1) Drill 4 holes into the wall or ceiling using the supplied template
- 2) Insert the ② anchors into the drilled holes
- 3) Match ④ (foot mount holes) to the drilled holes
- 4) Affix the mounting bracket by using ③ supplied screws

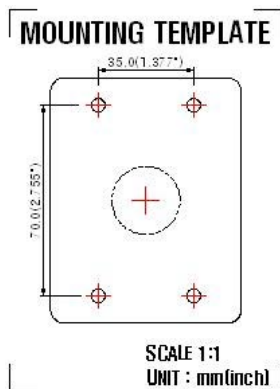

Installation on Wall

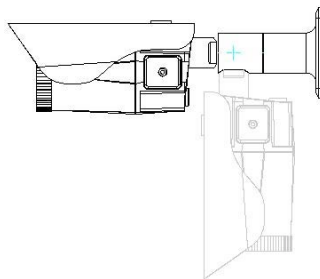

Installation on Ceiling

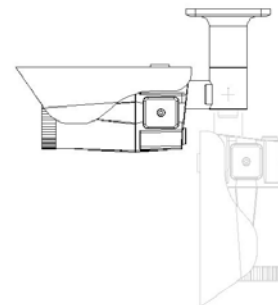

### 5.2. Power Supply Connections

The VTC-IRE40/3516 can operate on either 24AC or 12VDC, dual voltage power.

**It is required that the polarity-matched connection is made for 12VDC supply, otherwise IR LEDs, will not operate at night.**

Primary and secondary grounds are completely isolated to avoid possible ground-loop problems.

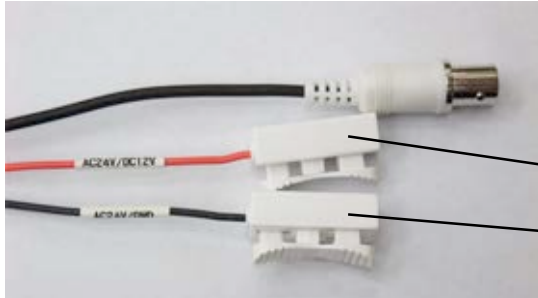

Clamp connectors of power input

AC24V/DC12V (RED WIRE)

AC24V/GND (BLACK WIRE)

### 5.3. Limit of pan and tilt

#### 1. Pan limit

Pan is limited to +/- 90°.

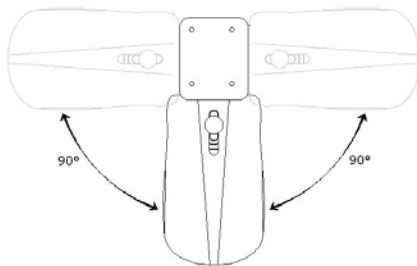

#### 2. Tilt limit

Tilt is limited to 0° (2°) min ~ 90° max.

Installation on Wall

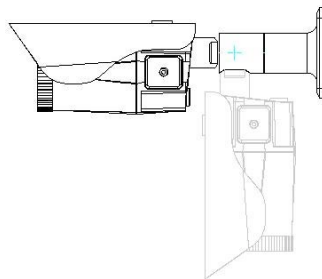

Installation on Ceiling

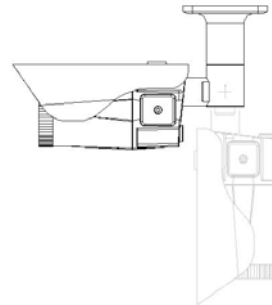

### 3. Inclination limit (horizontal image alignment)

Inclination limited to +/-90° max.

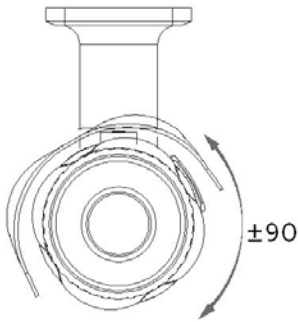

## 6. SETUP Menu

### 6.1 In the menu

The Setup menu can be accessed and controlled by the OSD control joy stick on the side of the camera. Five commands are available with the joy stick.



SYMBOL descriptions for joystick operation;



1. ▲, ▼, ◀, ▶ - Denotes the direction of Joystick lever operation.
2. ● - Denotes "ENTER" by pressing down on the Joystick lever

In the menu, use ▲, ▼ to move menu, ◀, ▶ to change the settings and press ● to select or enter.

The **FACTORY DEFAULT** in this manual may **NOT** be the same as the default values set by the **FACTORY** due to feature improvements or customer requirements.  
To enter the menu, press ●.

### 6.2 MAIN menu

Follow the chart below for submenu settings.

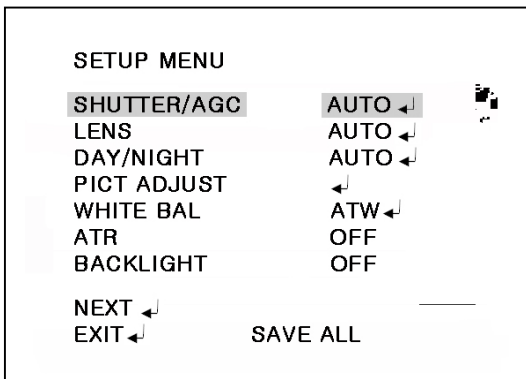

MAIN Menu-1

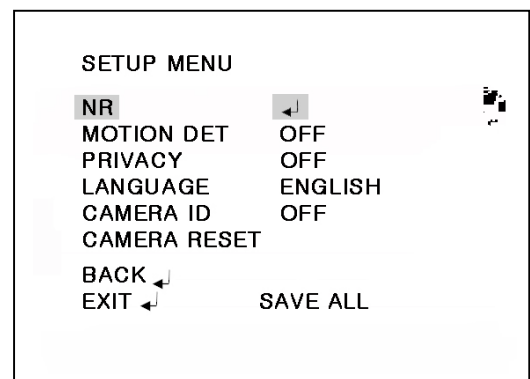

MAIN Menu-2

### 6.2.1 MAIN menu-1

MAIN menu-1	Default	Descriptions
SHUTTER /AGC	AUTO	Sets the parameters related to the shutter mode and AGC for AUTO and MANUAL settings. See '6.3 SHUTTER/AGC menu' for details.
LENS	AUTO	Selects the lens type, AUTO or MANUAL. AUTO supports DC auto-iris lens only. See '6.4 LENS menu' for details.
DAY/NIGHT	AUTO	DAY/NIGHT mode for AUTO only with IR LED version. <b>AUTO</b> - Camera switches DAY from/to NIGHT automatically by the built-in light sensor. BURST, DELAY CNT, DAY→NIGHT, NIGHT→DAY can be set. See '6.5 DAY/NIGHT menu' for details.
PICT ADJUST	-	Sets MIRROR, BRIGHTNESS, CONTRAST, SHARPNESS, HUE or GAIN. See '6.6 PICT ADJUST menu' for details.
WHITE BAL	ATW	Sets ATW, PUSH, USER1, USER2, ANTI CR, MANUAL or PUSH LOCK. See '6.7 WHITE BAL menu' for details.
ATR	OFF	Sets ON/OFF for enabling/disabling ATR (Adaptive Tone Reproduction) compensation for the better dynamic range (E-WDR) of the image. See '6.8 ATR menu' to adjust the dynamic ranges.
BACKLIGHT	OFF	Selects BACKLIGHT mode out of OFF, HLC or BLC. Areas and gains for HLC and BLC are factory preset and not user adjustable.
NEXT		Moves to MAIN menu-2.
EXIT		Exits the setup menu. To save the changes, move cursor to 'SAVE ALL' and press ● button before exiting the setup menu
SAVE ALL		Saves all parameters by pressing ● button when cursor is on 'SAVE ALL'

### 6.2.1 MAIN menu-2

MAIN menu-2	Default	Descriptions
NR	-	Sets the noise reduction parameters for NR MODE and Y LEVEL, C LEVEL. See '6.10 NR menu' for details.
MOTION DET	OFF	Sets ON/OFF for enabling/disabling MOTION DET. See '6.11 MOTION DET menu' for the parameter settings.
PRIVACY	OFF	Sets ON/OFF for enabling/disabling PRIVACY. See '6.12 PRIVACY menu' for the parameter settings.
LANGUAGE	ENGLISH	Selects the language out of 7 languages.
CAMERA ID	OFF	Sets ON/OFF for enabling/disabling of ID display. Factory default ID is Software version of camera. User programmed camera ID will be lost and restored with Factory default ID by CAMERA RESET. See '6.13 ID menu' for editing ID.
CAMERA RESET		Restores FACTORY DEFAULT. To save the restored parameters, move cursor to 'SAVE ALL' and press ● button before exiting the setup menu.
BACK		Returns to MAIN menu-1.
EXIT		Exits the setup menu. To save the changes, move cursor to 'SAVE ALL' and press ● button before exiting the setup menu
SAVE ALL		Saves all settings by pressing ● button when cursor is on 'SAVEALL'

### 6.3 SHUTTER/AGC menu

This menu shows how to control/select SHUTTER, AUTO IRIS and AGC to get the optimum image for high luminance and the low luminance according to the scene.

For example, to reduce the “wash out” and extend the dynamic range for a highlighted scene, you will use SHUTTER+AUTO IRIS in outdoor daylight. This mode may show color rolling or video level hunting problems in a certain lighting condition such as fluorescent lights.

For Flickerless mode which reduces flicker by NTSC cameras under 50Hz light or PAL camera under 60Hz light, MAIN>SHUTTER/AGC>MANUAL>SHUTTER must be set to 1/100(NTSC), 1/120(PAL) and MAIN>SHUTTER/AGC>AUTO>MODE to AUTO IRIS. Normal shutter speed with an auto iris lens should be set to 1/60(NTSC) and 1/50(PAL) for the optimum sensitivity.

This is a complicated menu so please proceed with care when handling the Shutter.

To enter SHUTTER/AGC menu, press ● button at MAIN menu-1>SHUTTER/AGC.

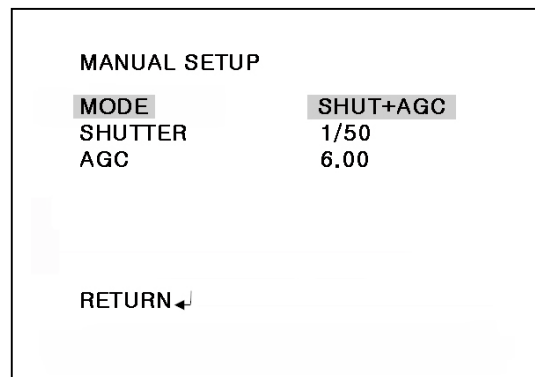
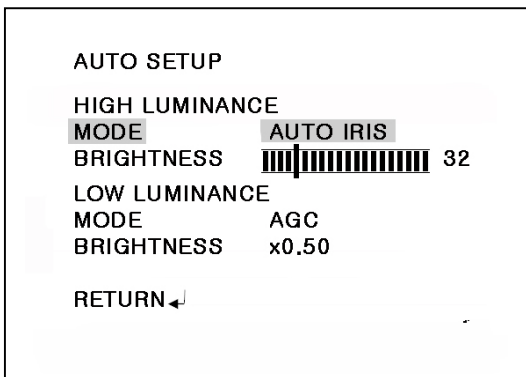

### 6.3.1 SHUTTER/AGC>AUTO SETUP menu

AUTO SETUP		Default	Descriptions
HIGH LUMINANCE	MODE	AUTO IRIS	<p>Sets the shutter mode from AUTO IRIS or SHUT+AUTO IRIS when in MAIN&gt;LENS&gt;AUTO menu, but it is fixed to SHUT if in the MAIN&gt;LENS&gt;MANUAL menu.</p> <p><b>AUTO IRIS</b> - Light level is controlled by an auto iris lens only. For proper auto iris operation, the auto iris operation mode in MAIN&gt;LENS&gt;AUTO&gt;MODE must be set to AUTO.</p> <p>The shutter speed is fixed to the setting at MAIN&gt;SHUTTER/AGC&gt;MANUAL&gt;SHUTTER in this mode. Set SHUTTER to 1/60(NTSC) or 1/50(PAL) for the best sensitivity unless it is in Flickerless mode.</p> <p>To set Flickerless mode, MAIN&gt;SHUTTER/AGC&gt;MANUAL&gt;SHUTTER must be set to 1/100(NTSC), 1/120(PAL) and MAIN&gt;SHUTTER/AGC&gt;AUTO&gt;MODE to AUTO IRIS.</p> <p><b>SHUT+AUTO IRIS</b>- Light level is controlled by the combination of an auto iris lens and a shutter control to improve the highlight from wash-out and extend the dynamic range. Shutter speed can vary between 1/60 (1/50) ~ 1/10,000 sec.</p> <p>This mode can enhance the overall video quality of daylight but may show a smear in a bright spot light or may show color rolling or video level hunting under a certain lighting condition such as fluorescent lights.</p>
	BRIGHT-NESS	032	Adjusts the brightness of the image with an auto iris lens or a shutter speed control + an auto iris lens.
LOW LUMINANCE	MODE	AGC	Sets AGC to compensate the video level when the scene is dim.
	BRIGHT-NESS	x0.50	<p>Sets the brightness level which starts AGC from x0.25, x0.50, x0.75 and x1.0 of full video level.</p> <p>If set to x0.50, the camera will start AGC when the video level goes down below the 50% level.</p>

NOTICE : The setting AUTO IRIS at SHUTTER/AGC>AUTO SETUP>HIGH LUMINANCE MODE will be changed to SHUT+AUTO IRIS if MAIN menu-1>LENS is changed to MANUAL. As a result of this, the lens iris can NOT be fully opened when MAIN menu-1>LENS>AUTO IRIS> MODE is OPEN. This can be recovered by setting SHUTTER/AGC>AUTO SETUP>HIGH LUMINANCE MODE to AUTO IRIS.

### 6.3.2 SHUTTER/AGC>MANUAL SETUP menu

MANUAL SETUP	Default	Descriptions
MODE	SHUT +AGC	Compensates the video level by the manual shutter control and AGC.
SHUTTER	1/60 (1/50)	Sets the manual shutter to 1/60(1/50), 1/100(1/120), 1/250,1/500,1/1000, 1/2000,1/4000 or 1/10000. Manual shutter is only useful for scenes where luminance is unchanged.
AGC	6.00	Sets AGC gain in dB. Higher gain compensates brighter but noise increases. Manual AGC can be set to 6, 12, 18, 24, 30, 36, 42 or 44.8 dB.

### 6.4 LENS menu

To enter LENS menu, press ● button at MAIN menu-1>LENS>AUTO.

AUTO IRIS	
TYPE	DC
MODE	AUTO
SPEED	080
RETURN ↵	

AUTO IRIS	Default	Descriptions
TYPE	DC	<b>MUST BE SET TO DC ONLY.</b> This camera does NOT support video type auto iris lens.
MODE	AUTO	<b>AUTO</b> - Lens iris is automatically controlled according to the scene's light level. <b>OPEN</b> - Lens is fully opened regardless of the light level. <b>CLOSE</b> - Lens is fully closed.
SPEED	080	Adjusts the iris control speed. The lower the value, the faster the speed. If the speed is too slow or fast, the iris control may be unstable.

## 6.5 DAY/NIGHT menu

To enter DAY/NIGHT menu, press ● button at MAIN menu-1>DAY/NIGHT.

DAY/NIGHT	
BURST	OFF
DELAY CNT	████████████████████ 005
DAY → NIGHT	████████████████████ 005
NIGHT → DAY	████████████████████ 032
RETURN ↵	

B/W	
BURST	OFF
RETURN ↵	

### **IMPORTANT ACTIVITY!!!**

**DAY->NIGHT and NIGHT->DAY operations must be examined and verified at the final installation.**

Block the lens for a few seconds for NIGHT mode then release and let it return to DAY mode.

If camera stays at NIGHT mode for more than 10sec, slightly decrease NIGHT→DAY THRES and repeat the fore-mentioned steps.

If the scene is too dim or lens iris was adjusted too low (near close) it may not return to DAY

DAY/NIGHT	Default	Descriptions
BURST	OFF	<b>BURST</b> determines whether a color burst signal keeps output or is eliminated when the camera switches to B/W. If set to ON, B/W video signal contains color burst signal and is compatible with the color equipment but shows the same resolution as color video. If set to OFF, the color burst signal is removed from B/W video and shows better resolution but it is possible that a compatibility problem may occur with the color equipment.
DELAY CNT	005	<b>DELAY CNT</b> is the time in seconds that the camera maintains its status before Day↔Night switches. DELAY can avoid the unwanted/frivolous switching due to short term lights such as light from a passing car.
DAY → NIGHT	005	<b>DAY → NIGHT</b> is a threshold level which determines the switch from DAY to NIGHT. A lower (higher) value makes the camera switch from Day to Night at lower (higher) illumination. If it stays in Day (Color) mode at night time, increase <b>DAY → NIGHT</b> threshold value until it switches to Night. <u>Examine and verify Day/Night operation according to IMPORTANT ACTIVITY.</u> <b>CAUTION</b> If the gap between <b>DAY → NIGHT</b> and <b>NIGHT → DAY</b> is not big enough, camera may repeatedly switch from Day↔Night.

NIGHT→ DAY.	3	<p><b>NIGHT→DAY</b> is a threshold level that determines the switch from NIGHT to DAY. A lower (higher) value makes the camera switch from Night to Day at lower (higher) illumination.</p> <p>If it stays in Night (B/W) mode at day time, decrease <b>NIGHT→DAY</b> threshold value until it switches to Day.</p> <p><u>Examine and verify Day/Night operation according to IMPORTANT ACTIVITY.</u></p> <p><b>CAUTION</b> If the gap between DAY→NIGHT and NIGHT→DAY is not big enough, camera may repeatedly switch from Day↔Night.</p> <p>If NIGHT→DAY is decreased from the Factory default, the same amount is recommended for DAY→NIGHT to avoid repeating DAY↔NIGHT unintentionally.</p>
----------------	---	--

### 6.6 PICT ADJUST menu

To enter PICT ADJUST menu, press ● button at MAIN menu-1>PICT ADJUST.

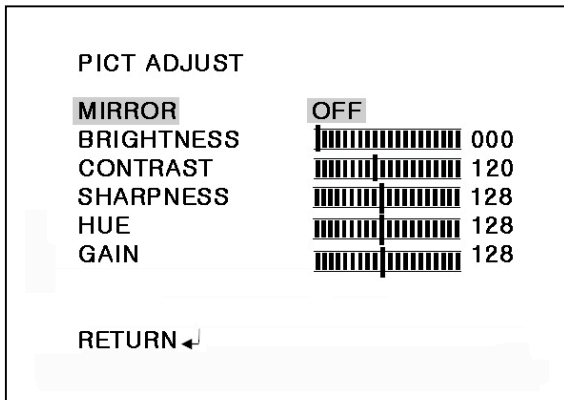

PICT ADJUST	Default	Descriptions
MIRROR	OFF	Picture will be flipped horizontally if it turns ON.
BRIGHTNESS	000	Increases or decreases the brightness of the picture. This is different from that of DC iris lens and simply increases or decreases the digital gain of the video. Do not increase this too much, the dynamic range for the highlight area will decrease.
CONTRAST	120	Increases or decreases the contrast of the picture.
SHARPNESS	128	Increases or decreases the sharpness of the picture. Note: Too much sharpness can make the image appear harsh and will show more noise. It may also show line flicker at the edge of object in the picture.
HUE	128	Adjusts hue for NTSC version only.
GAIN	128	Increases or decreases the color gain of the picture.

## 6.7 WHITE BAL menu

White balance can be set to **ATW**, **PUSH**, **USER1**, **USER2**, **ANTI CR**, **MANUAL** or **PUSH LOCK**. ATW (Auto Tracking White balance) and PUSH (Full pull-in) is continuously monitoring/analyzing the color temperature of the incoming light and correcting the white balance.

**ATW** limits the color temperature range to about 2,500°K~8,500°K to reduce the excessive compensation for a large object that has a single color.

**PUSH** has no limits between about 1,800°K~10,500°K, but it may over-compensate the white balance for a large object that has a single color.

In cases under 2,500°K such as halogen light, ATW may stop and if so, PUSH mode is recommended.



**USER1** and **USER2** are a fixed white balance which is user-programmable by R-GAIN and B-GAIN and useful only for consistent/steady lighting.

**ANTI CR** (Anti Color Rolling) can reduce color rolling under fluorescent lighting when the camera operates in shutter control mode without an auto iris lens. (NTSC version only).

**MANUAL** white balance is a kind of fixed white balance that is user-programmable by B-GAIN, (R-GAIN will be automatically adjusted in accordance with B-GAIN) and useful only with consistent/steady lighting.

**PUSH LOCK** is a fixed white balance where the white balance is compensated only while ● button is pressed at MAIN>WHITE BAL>PUSH LOCK and finishes the white balance when ● button is released.

To enter ATW (MANUAL) menu, press ● button at MAIN **menu-1**>WHITE BAL>ATW(MANUAL).

ATW	
<b>SPEED</b>	 250
DELAY CNT	 001
ATW FRAME	X2.00
ENVIRONMENT	INDOOR
RETURN ↵	

MANUAL WB	
<b>LEVEL</b>	 064
RETURN ↵	

ATW	Default	Descriptions
SPEED	250	Sets the AWB compensating speed. Lower value makes AWB faster. <b>CAUTION</b> If AWB is too fast, it may produce color oscillation.
DELAY CNT	001	Adjusts the AWB compensation period to next update of AWB. The smaller value will update AWB more frequently.
ATW FRAME	X2.00	Determines the ATW range with respect to the fundamental range. A higher value than x1.00 will extend the ATW range at lower and higher color temperature.
ENVIRONMENT	INDOOR	Selects INDOOR or OUTDOOR. The ATW is optimized for limited applications. <b>INDOOR</b> - Optimized for Indoor installation and it compensates ATW for low color temperature such as incandescent lights. <b>OUTDOOR</b> - Optimized for outdoor sunlit applications and compensates ATW for high color temperature such as daylight.

MANUAL WB	Default	Descriptions
LEVEL	064	Adjusts the manual white balance by LEVEL, (B-GAIN).

## 6.8 ATR (Adaptive Tone Reproduction) Menu

The ATR feature improves the dynamic range and the visibility of the image by providing optimal gradation compensation of the image in one field. This is achieved by two ways of image processing, luminance compression and contrast enhancement, so that the tone can be enhanced in highlight and dark areas.

To enter ATR menu, press ● button in MAIN menu-1>ATR.

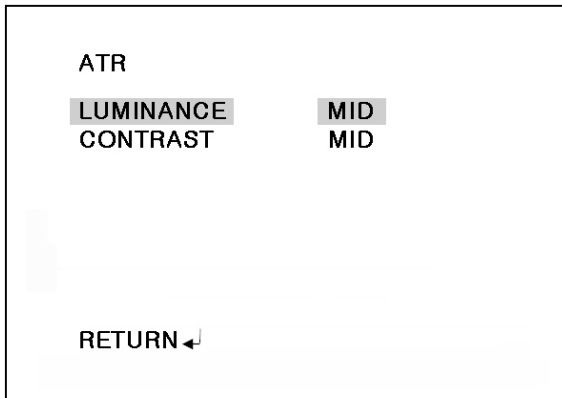

ATR	Default	Descriptions
LUMINANCE	MID	Compresses the highlight area and enhances the dark area so that the entire image can converge toward the medium level. LOW will compensate minimally and HIGH will level out the image more. With a HIGH setting, the image may look less contrastive and noise may increase in the dark area.
CONTRAST	MID	Adjusts the strength of the image contrast. If set to too high, the dark area may lose detail and the high luminance area may saturate.

## 6.9 BACKLIGHT menu

To enter BACKLIGHT menu, press ● button in MAIN menu-1>BACKLIGHT.

The Backlight Compensation - BLC - function is used to brighten an image in the foreground with a highly lit area behind it such as sunlight, limiting the affect of silhouetting.



The Highlight Compensation - HLC - function is used to black out highlighted areas that may blind the camera, in order to enable a clear visual image of objects, such as the license plates of an oncoming vehicle or other objects that may be obstructed by headlamps.



## 6.10 NR menu

To enter the NR menu, press ● button in MAIN menu-2>NR.

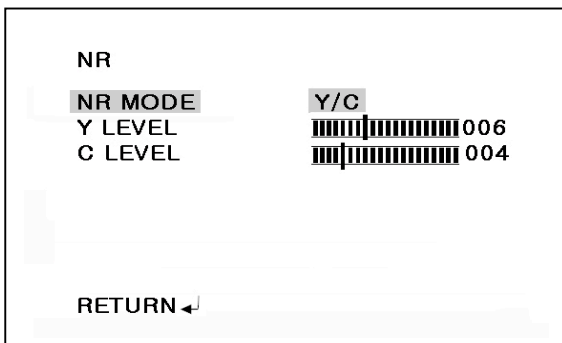

NR	Default	Descriptions
NR MODE	Y/C	Selects OFF, Y, C or Y/C, which noise reduction is performed with.
Y LEVEL	006	Indicates the noise reduction strength for the luminance signal. A higher value performs a stronger noise reduction, which makes the image less sharp.
C LEVEL	004	Indicates the noise reduction strength for the chrominance signal. A higher value performs a stronger noise reduction and makes the image less sharp.

### 6.11 MOTION DET menu

Up to 4 motion detection areas are available and each area is programmable in size and location. The motion is displayed by means of blocks when MAIN **menu-2**>MOTION DET and MOTION DET>BLOCK DISP are ON.

To enter MOTION DET menu, press ● button in MAIN **menu-2**>MOTION DET>ON.

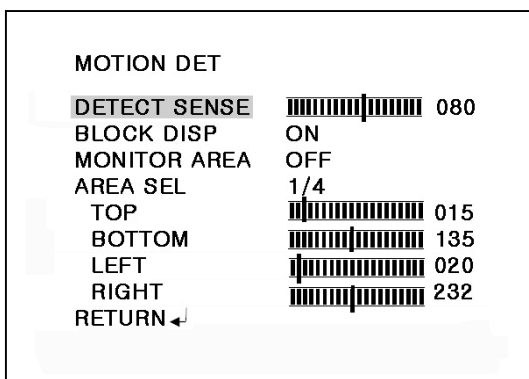

MOTION DET	Default	Descriptions
DETECT SENSE	080	Adjusts the sensitivity for detecting motion. Higher value is more sensitive.
BLOCK DISP	ON	Enables or disables display blocks for the area where motion is detected.
MONITOR AREA	OFF	Displays four motion windows as programmed in sizes and positions.
AREA SEL	1/4	Selects one of AREA1~AREA4 to be adjusted. TOP (BOTTOM) - ◀ button moves up and ▶ button moves down the top (bottom) border of the selected window at AREA SEL. LEFT (RIGHT) - ◀ button moves left and ▶ button moves right the left (right) border of the selected window at AREA SEL

## 6.12 PRIVACY menu

Up to 8 privacy areas are available and each area is programmable in size and location. The number of privacy areas is limited to four when MOTION DET>MONITOR AREA is ON. The privacy areas are masked with the color selected by PRIVACY>COLOR.

To enter PRIVACY menu, press ● button in MAIN menu-2>PRIVACY>ON.

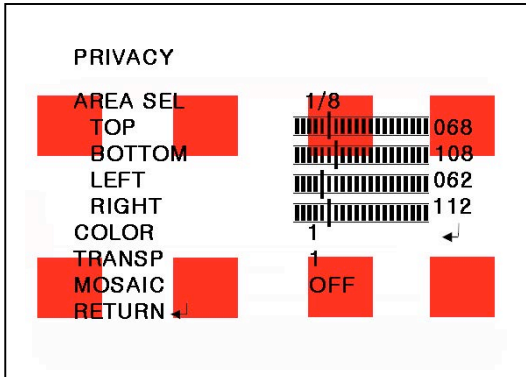

PRIVACY	Default	Descriptions
AREA SEL	1/8	Selects one of AREA1~AREA8 to be adjusted. TOP (BOTTOM) - ◀ button moves up and ▶ button moves down the top (bottom) border of the selected window at AREA SEL. LEFT (RIGHT) - ◀ button moves left and ▶ button moves right the left (right) border of the selected window at AREA SEL
COLOR	1	Sets one of 8 colors for the selected mask window at AREA SEL.
TRANSP	1.00	Transparency rate for the mask can be adjusted. 0.00 - Mask is fully transparent and not visible. 0.50 - Mask is 50% transparent. 0.75 - Mask is 25% transparent. 1.00 - Mask is not transparent.
MOSAIC	OFF	Enables or disables the mosaic effect for the selected mask window at AREA SEL

## 6.13 LANGUAGE menu

ENGLISH, JAPANESE, DEUTCH, FRANCAIS, RUSSIAN, PORTUGUES and ESPANOL

## 6.14 CAMERA ID menu

Up to 40 characters can be used/input for camera ID.

To enter CAMERA ID menu, press ● button in MAIN menu-2>CAMERA ID.

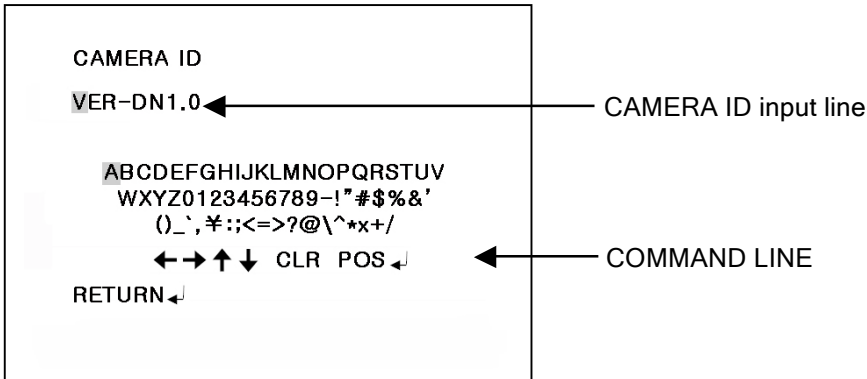

Use ▲, ▼, ◀, ▶ buttons to move a block cursor over the character table and press ● button to input the selected character.

To move the character input position on CAMERA ID input line, move a cursor to ←→ on COMMAND LINE and press ● button on ← or →.

To clear CAMERA ID input line, move a cursor to CLR on COMMAND LINE and press ● button.

To set the location of CAM TITLE to be displayed on the monitor, move a cursor to POS and press ● button and then menu disappears and CAMERA ID will be displayed on the monitor.

Move CAMERA ID by using ▲, ▼, ◀, ▶ buttons and press ● button to fix.

Menu will appear again. To finish CAM TITLE menu, press ● button on RET on command line.

## 6.15 CAMERA RESET

Camera loads Factory defaults.

To save them, go to SAVE ALL and press ● button.

## 6.16 EXIT

Exits SETUP MENU and returns to the normal display

## 7. Specifications

Model Name	VTC-IRE40/3516	
Image Device	1/3" High Density Sony EX-VIEW CCD & Effio-E DSP (960H)	
Effective Pixels	976(H) x 494(V)	976(H) x 582(V)
Resolution	700 TV lines	
Minimum illumination	0.003Lux / F1.2 (0 Lux with IR LEDs ON)	
Infrared LEDs	40 840nm IR LEDs	
IR Distance	Over 150 Feet	
Beam Spread	50 degree	
Day/Night	True Day/Night by ICR	
S/N Ratio	More than 50dB with AGC OFF at 50IRE	
Electronic Iris	1/60 to 1/100,000 sec.	
Built-In Lens	3.5-16mm DC A/I, Switched IR Cut Filter D/N Lens	
Light Compensation	HLC (Highlight Compensation) / BLC (Backlight Compensation)	
Iris Mode	DC Drive Iris Control (Internally Fixed)	
Gain Control	Auto	
White Balance	1,800~10,500°K Automatic Tracking	
Video Output	VBS 1 Vpp +/- 10%, 75ohm	
TV System	2:1 Interlace	
Scan Frequency	59.94Hz(V), 15.734Khz(H)	50Hz(V), 15.625Khz(H)
Synchronization	Internal/Line Lock (Default: Internal)	
Noise Reduction	2DNR	
E-WDR	YES by ATR (Adaptive Tone Reproduction)	
Motion Detection	YES (24x 16 BLOCK ALARM AREA)	
Privacy Mask	Up to 8 Programmable Mask Areas	
Flicker Reduction	Yes	
OSD Language	English, Japanese, German, French, Russian, Portugese, Spanish	
Water Resistance	IP68	
Construction	Aluminum Housing	
Power Source	12VDC/24VAC (Dual Voltage)	
Power Consumption	IR ON: 450mA (12VDC) / 460mA (24VAC) / IR OFF: 110mA (12VDC) / 120mA (24VAC)	
Operating Conditions	-4°F ~ 122°F (-20°C ~ 50°C) / 85% RH Max	
Length	Ceiling Mounted: 9.5" (241mm) / Wall Mounted: 11.375" (289mm)	
Width	Camera: 3" (76mm) / Camera w/Sun Shield: 4.375" (111mm)	
Height	Ceiling Mounted: 6" (152mm)	
Weight	2.65 lbs. (1202g)	

- Design and specifications are subject to change for product improvements without prior notice.

### 8. Dimensional Drawings

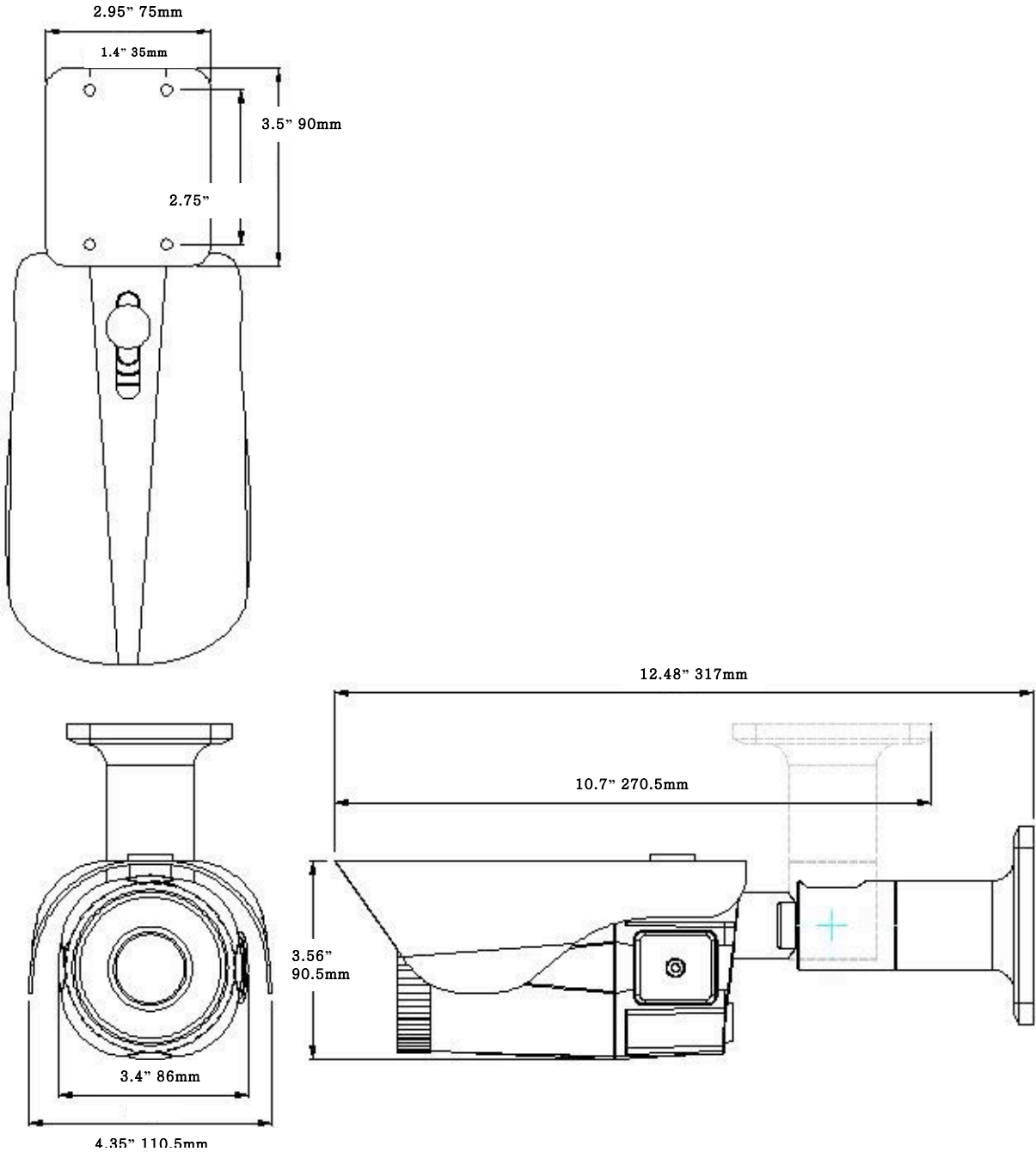



# **VITEK LIMITED PRODUCT WARRANTY**

VITEK products carry a three (3) year limited warranty. VITEK warrants to the purchaser that products manufactured by VITEK are free of any rightful claim of infringement or the like, and when used in the manner intended, will be free of defects in materials and workmanship for a period of three (3) years, or as otherwise stated above, from the date of purchase by the end user. This warranty is non-transferable and extends only to the original buyer or end user customer of a VITEK Authorized Reseller.

The product must have been used only for its intended purpose, and not been subjected to damage by misuse, willful or accidental damage, caused by excessive voltage or lightning.

The product must not have been tampered with in any way or the guarantee will be considered null and void.

This guarantee does not affect your statutory rights.

Contact your local VITEK Reseller should servicing become necessary.

VITEK makes no warranty or guarantee whatsoever with respect to products sold or purchased through unauthorized sales channels. Warranty support is available only if product is purchased through a VITEK Authorized Reseller.

Visit [www.vitekctv.com](http://www.vitekctv.com) to register your product warranty and receive periodic updates.



28492 CONSTELLATION ROAD VALENCIA, CA 91355  
WWW.VITEKCCTV.COM | 888-VITEK-70