



VT-IPSD102H Dual Streaming IP Server with H.264 Compression



- High quality of compression algorithm (H.264/MJPEG)
- H.264 + H.264 / H.264 + MJPEG Dual Streaming
- Encoder/Decoder selectable
- Full-duplex audio/video transmission
- 30fps/25fps @ full D1 resolution
- 1:N Multi-casting and relayed data transmission
- Protocols : TCP/IP, Multicast, HTTP, SMTP, SNMP, FTP, DHCP, DNS, Dynamic DNS, RTP, RTSP
- Real time monitoring/recording/playback through CMS viewer S/W and Internet Explorer
- Dynamic IP support with Dynamic DNS
- Power over Ethernet(PoE) support
- Data storage against network failure or event (USB2.0)
- Watchdog for system recovery
- Support for PTZ and Controller
- Motion detection

VITEK

Safety Precaution

- ◇ Make sure to turn off the power before installing the VT-IPSD102H.
- ◇ Do not install under direct sunlight or in dusty areas.
- ◇ Make sure to use the product within the temperature and humidity that is specified.
- ◇ Do not operate the product in the presence of vibrations or strong magnetic fields.
- ◇ Do not put electrically conducting materials in the ventilation hole.
- ◇ Do not open the top cover of the product. It may cause a failure or electric shock on the components.
- ◇ To prevent from overheating, make sure to keep the distance at least 10cm from the ventilation hole.
- ◇ Check for proper voltage before connecting the power.

Table of Content

Table of Content 2

1. Introduction 4

 1. About User Manual 4

 2. Feature..... 4

 3. Product and Accessories 6

 4. Part Names and Description 7

 5. System Modes and Connections 9

2. Installation 12

 1. Connecting Video..... 12

 2. Connecting Audio..... 12

 3. Connecting Serial Ports 12

 4. Connecting Sensor and Alarm 12

 5. Connecting Power..... 12

 6. Checking Operating 13

3. System Operation 14

 1. LED Display 14

 2. Remote Video Monitoring 15

 3. Initialization of IP Address..... 16

4. Remote Configuration 17

 1. Remote Configuration 17

 2. Encoder Configuration 17

 2.1 System Configuration 18

 2.2 Video Configuration 20

 2.3 Audio Configuration 24

 2.4 Network Configuration 25

 2.5 Serial Port Configuration 28

 2.6 Event Configuration 30

 2.7 Preset Configuration 33

 2.8 User Configuration..... 34

 3. Decoder System 36

 3.1 Video Configuration 36

 3.2 Network Configuration 37

 3.3 Event Configuration 39

5. ENVI Visual Management Software (VMS) 41

 1. ENVI Visual Management Software 41

 2. Server Registration and Removal 41

 3. Server Connection Management 43

4. Server Status Monitoring	44
5. Network and System Diagnostics	45
6. F/W Upgrade.....	48
7. Remove Configuration and Video Monitoring	49
6. Trouble Shooting	49
Appendix A: Sensor and Alarm Port.....	50
1. Sensor Port	50
2. Alarm Port	50
Appendix B: Serial Port.....	51
1. RS-232 Port	51
2. RS-422/485 Port	51

1. Introduction

1. About User Manual

This user manual provides information on operating and managing the optimal video surveillance system, VT-IPSD102H. The manual includes instructions for installation, operation and configuration of VT-IPSD102H as well as how to troubleshoot.

2. Feature

VT-IPSD102H is a video and audio surveillance transmission system based on IP network through LAN, ADSL/VDSL, and Wireless LAN. The VT-IPSD102H series operates as one of two modes: Encoder or Decoder. The Encoder system compresses and transmits video data. Decoder receives and decompresses the video data.

■ Video

- High-quality compression algorithm, H.264 & MJPEG support
- Compression in various resolution: CIF, Half-D1 and D1
- Wide range of video transmission rate: 32kbps ~ 8Mbps
- Various transmission mode: CBR and VBR
- Motion Detection

■ Audio

- Multi-transmission mode: Uni-direction (Encoder -> Decoder, Decoder -> Encoder), Bi-direction

■ Network

- Fixed IP & Dynamic IP (DHCP) support
- 1:1, 1:N support
- Multicasting
- Automatic transmit rate control according to network condition

■ Serial Data

- Two serial ports
- Various PTZ camera protocol
- Data pass-through mode: Serial data communication between Encoder – Decoder

■ Sensor and Alarm

- Support direct connections of external sensor and alarm devices.
- Event Alarm

■ USB

- Connection to internal or external USB storage for remote access

■ User Interface

- System status display utilizing OSD (On Screen Display)
- Diagnose and upgrade through dedicated program called ENVI VMS
- System configuration using Internet Explorer

■ High Reliability

- Reliable embedded system
- System recovery utilizing dual watch-dog functions

3. Product and Accessories

VT-IPSD102H

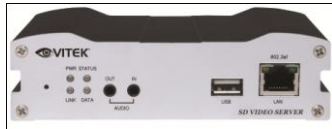

Quick Manual

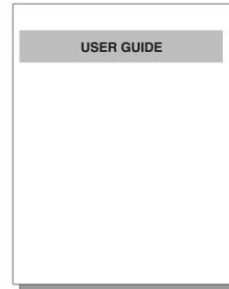

Power adaptor and cable

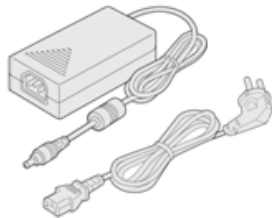

User Manual & SW CD

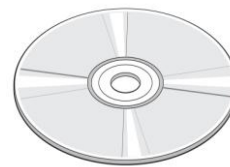

Screws



Brackets

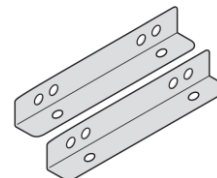

<Picture 1> Product and Accessories

4. Part Names and Description

■ Front View

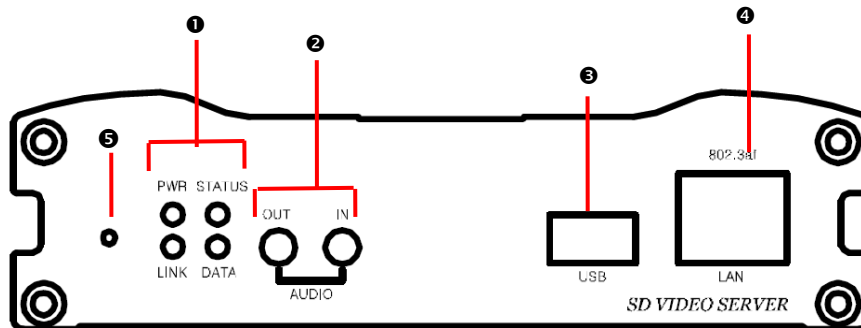

Parts	Function
❶ LEDs	Display power On/Off condition, Link, Status and Data
❷ Audio In, Out	Audio Input and Output
❸ USB	USB port for any USB device
❹ LAN(Ethernet)	100/10-base-T Ethernet interface
❺ Reset button	Initialization of network setting

■ Rear View

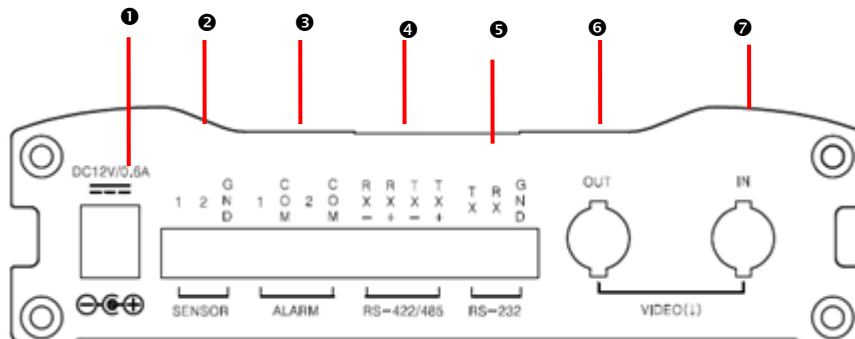

Terminal	Function
❶ POWER IN	DC 12V power input
❷ SENSOR	Sensor input
❸ ALARM	Relay output
❹ RS-422/485 (COM2)	Serial port 2 (COM2) for PTZ control and etc. Support RS-422 and RS-485 protocol
❺ RS-232 (Com1)	Serial Port 1 (COM1) for PTZ control and etc. Support RS-232 protocol
❻ VIDEO OUT	Video output
❼ VIDEO IN	Video input

5. System Modes and Connections

The VT-IPSD102H system operates in one of two modes: Encoder or Decoder. The VT-IPSD102H system can be connected in either a '1-to-1' fashion, where one encoder is connected to one decoder, or a '1-to-many' fashion, where one encoder is connected to many decoders.

The following chart shows possible combinations of video, audio and serial data transmission.

System Mode	Video	Audio	Serial Data
Encoder	Transmit	Transmission/Receive	Transmit/Receive
Decoder	Receive	Transmission /Receive	Transmit/Receive

Therefore, the system modes are defined by the video communication and all system modes are capable of bi-directional transmission of audio or serial data.

■ Topology

Generally, the encoder and the decoder are connected in a 1-to-1 mode. To support specific situations, 1-to-many connection is also supported.

◆ 1:1 Connection (Unidirection)

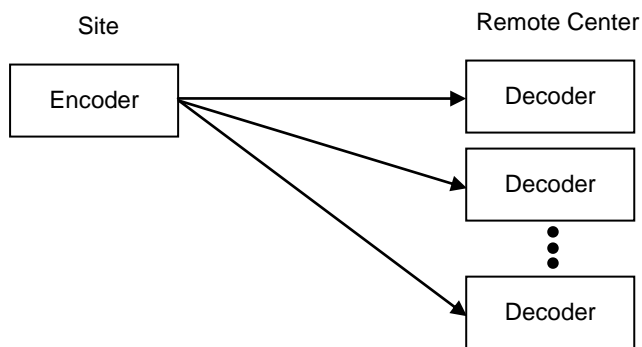

The most commonly used configuration is the 1 to 1 connection. An encoder is installed at a site where video images can be transmitted and a decoder is installed at a center location to receive and view the video images on analog monitor. Audio and serial data are transferred in either direction.

◆ 1:N Connection (Unidirection)

In this configuration, a site can be monitored from many remote center locations. Although up to 64 decoders can be connected to one encoder, in the real network environment, network bandwidth can limit the maximum connections.

Functionally, the VMS (Video Management System) software can replace the decoder.

◆ Multicast Mode

In 1:N Connection, the network that supports multicasting, a large number of decoders, can receive video efficiently from an encoder transmitting a single streaming of video and audio.

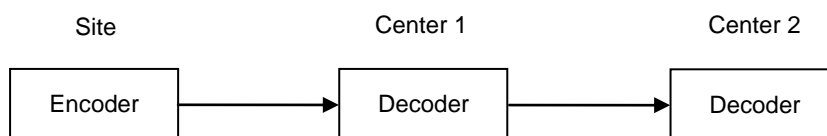
◆ Relaying

In this arrangement, video and audio can be retransmitted from one center to another center. The arrangement is useful when the network bandwidth to the site is limited while there is more than one center wanting to monitor the site.

◆ VMS (Video Management System)

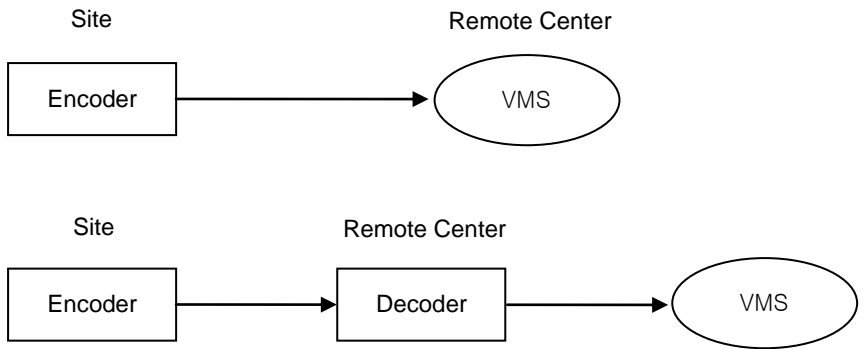

VMS SW is a Windows based remote monitoring program to access multiple encoders for real-time monitoring or control of the encoders and connected cameras. Please refer to VMS User Manual for more information on VMS.

2. Installation

1. Connecting Video

◆ Encoder System

- Connect the camera video output line to the encoder VT-IPSD102H video input port.

◆ Decoder System

- Connect the monitor video input line to the decoder VT-IPSD102H video output port.

2. Connecting Audio

Audio is bi-directional in any configuration regardless of the system mode. If necessary, it can be configured to be in transmit-only, receive -only or bi-directional mode.

- Connect audio input and output ports to audio devices accordingly.
- Audio signal is in line level, therefore, microphone or speaker with amplification function should be used.

3. Connecting Serial Ports

For camera control, the PTZ controller (keyboard) and receiver can be connected to serial ports. Two corresponding serial ports in encoder and decoder which are connected in 1-to-1 fashion works in pass-through mode. This means that commands at a local system's COM1 port will be transparently passed to the remote system's COM1 port. Also, a command at a local system COM2 port will pass to the remote system's COM2 port.

4. Connecting Sensor and Alarm

Connect sensor and alarm devices to corresponding terminals.

5. Connecting Power

After confirming the power source, connect power adaptor and connect the 12VDC connector to the system.

6. Checking Operating

Once the power is supplied to the camera, it will start booting. The system will boot up to an operating mode after approximately 40-60 seconds. The green LED on the Ethernet port will flash indicating the system is ready.

Software provided on the disc called ENVI VMS allows you to check the IP address and other network details of the camera.

◆ Encoder LED Display

PWR	STATUS	LINK	DATA
○	○	○	○
Red	Green Blinking	OFF	OFF

The above LED status display shows that neither camera or decoder are connected. Once the encoder is connected to a decoder, the color of link LED will light in green and the LED will blink as video or audio transmissions occur.

◆ Decoder LED Display

PWR	STATUS	LINK	DATA
○	○	○	○
Red	Green Blinking	Red Blinking	OFF

The above LED status display shows that the encoder has started without connecting to an encoder. Once an encoder is connected, the color of link LED will be changed to green and the LED will blink as video or audio data transmissions occur.

3. System Operation

1. LED Display

■ Description of LEDs

System status can be monitored with LEDs.

LED	State	Description
PWR	Off	No power
	Red	Power on
STATUS	Green blinking	Normally operating
	Red	System failure: Needs diagnostics
	Constant change of colors between Red and Green	NTSC/PAL setting does not match with input video signal
	Red Blinking	Failed to obtain IP address in DHCP mode
	Constant change of colors between Green blinking 2 times and Red blinking once	Failed to register on DDNS server
	Green blinking, Red blinks once every 5 seconds	Video loss in Encoder system
	Orange blinking	Improper resolution setting in duplex mode
LINK	Off	No connection to remote system
	Green	Connected to a remote system
	Red blinking	Decoder only: trying to connect to an Encoder
	Orange	Illegal connection (unsupported combination of system modes)
DATA	Green	Data transmission in progress
	Red	Data loss
	Off	No data transmission

2. Remote Video Monitoring

There are two ways to view the remote video when the connections are completed between a site and center system. In order for a proper operation, an IP address must be set accordingly.

■ Video Monitoring with Decoder System

Once the encoder IP address is set in the remote IP address section of the decoder, the decoder system will connect to the encoder system and start receiving the video images. Normally, a monitor connected to the decoder will display video images.

■ Video Monitoring using Internet Explorer

If the VT-IPSD102H's IP address is entered in Internet Explorer, the system will ask for confirmation to install Active-X control. Once authorized, Internet Explorer will start to display video images from the encoder as shown below.

<http://192.168.10.100>

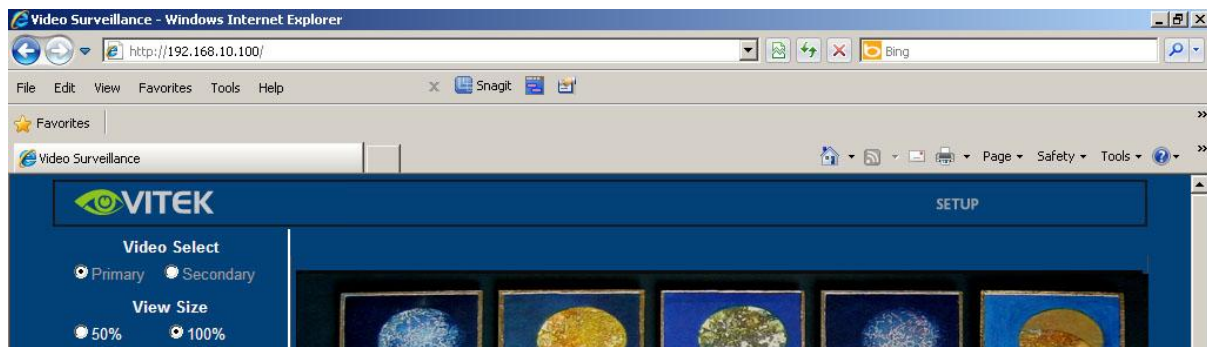

■ Video Selection

If Primary is selected, Max. 720 x 480 (NTSC) or 704 x 756 (PAL) via H.264 compression algorithm video can be displayed. And once activated Dual Video compression and Secondary may be selected, H.264 or MJPEG compression algorithm video can be displayed in this case.

■ Screen Size:

Adjustable Screen Size

■ Digital Zoom:

Max 5x Digital Zoom is available.



■ Focus Near, Focus Far, Auto Focus

Adjust the focus

■ Sensor Input

When the sensor on the VT-IPSD102H is connected and working, the light turns red.

■ Alarm Output

Alarm Output button can trigger an event directly from the Live View page.

■ Snapshot

Snapshot button saves a snapshot of the video image currently on display. Captured picture can be stored as BMP or a JPEG file.

■ Talk

Transfer audio to audio device connected to the VT-IPSD102H.

3. Initialization of IP Address

If a system IP address is lost, the system can be reset to a known IP address using the reset button in the back side of the system:

- ① While system is in operation, press the reset button for 5+ seconds.
- ② The system will reboot automatically
- ③ Once the system has been rebooted, the IP address will be set to the following.
 - IP mode: Fixed IP
 - IP address: 192.168.10.100
 - Subnet mask: 255.255.255.0
 - Gateway : 192.168.10.1
 - Base port : 2222
 - Http port : 80

4. Remote Configuration

1. Remote Configuration

The server can be configured using a web browser. Type the IP address of VT-IPSD102H in the address input area of Internet Explorer, then a live viewing screen will be displayed. Press **Setup** button located in the upper right area of the monitoring screen, then the server setup page will be displayed.

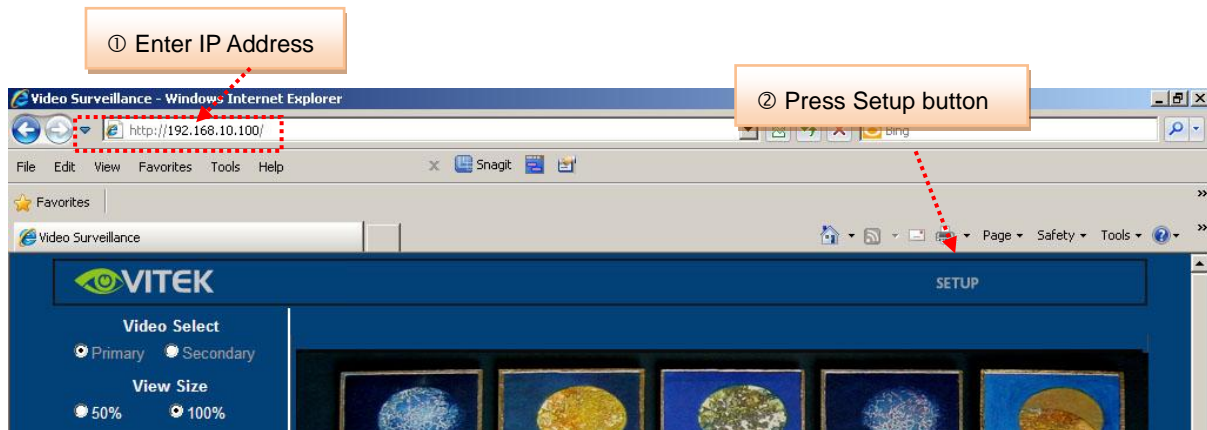

The remote configuration window may be slightly different depending on the system modes (Encoder, Decoder). The general explanation of the configuration in this manual is based on Encoder system and differences according to the modes will be clarified when needed.

The configurations are grouped into 8 categories: **System**, **Video**, **Audio**, **Network**, **Serial**, **Event**, **Preset** and **User**. No configuration changes are applied until **Apply** is pressed. Leaving the page without pressing **Apply** will discard any changes.

2. Encoder Configuration

While most configuration items are common for Encoder, Decoder and Duplex mode, there are items that are relevant to specific system mode. All the configuration items for Encoder mode were explained first. Then, items specific only to Decoder and Duplex modes are described respectively. Sections for Decoder and Duplex will not include items common for all modes.

2.1 System Configuration

The screenshot shows the VITEK web-based configuration interface. At the top, there is a navigation menu with tabs for System, Video, Audio, Network, Serial, Event, Preset, Record, User, and Camera. The 'System' tab is selected, and the 'System' section is highlighted in red. Below this, there are four main configuration sections: General, Firmware, Time, and Reboot/Factory Reset.

General

- System ID: [Text Input]
- BurnIn OSD System ID: [Text Input] (alphanumeric characters only)
- Language: English [Dropdown]
- [Apply]

Firmware

- Version: Enc:V1.103C-001 [Text Input]
- Board ID: 63 [Text Input]
- Upgrade: [Button] [Browse...] [Firmware Upgrade]

Time

- Start Time: 2011/05/27 6:10:16 [Text Input]
- Current Time: 2011/05/27 7:27:05 [Text Input] [Set Current Time]
- Time Format: YYYY/MM/DD hh:mm:ss [Dropdown]
- Time Zone: (GMT-12:00) International Date Line West [Dropdown]
- Automatically synchronize with NTP server
- NTP Server Name: pool.ntp.org [Text Input]
- [Apply]

Reboot

- [Reboot]

Factory Reset

- [Factory Reset]

- System Mode

System mode: Select Encoder, Decoder

- System ID

System ID: Alphanumeric System ID to be transferred to remote software

- Language

Language to be used for web-based configuration

- Firmware version

Current firmware version

- Board ID

Network board ID of VT-IPSD102H recognized by system

- Start Time

Latest system boot date and time

- Current Time

Current date & time: Enter a new date and time and press **Set Current Time** button to update date & time.

- Time Zone

Time zone: Select time zone of where the system is installed. Depending on the time zone, Daylight Saving Time will work automatically.

- Automatically synchronize with NTP server

Synchronize system time with an NTP server using NTP (network time protocol). Name of the NTP server should be registered on NTP server Name.

- Reboot Server

Pressing **Reboot Server** button will cause the system to reboot. Do not press the Reboot button unless the server needs a reboot.

- Factory Reset

Set all settings to the factory default values. System log and user registrations are also cleared.

2.2 Video Configuration

LIVE VIEW

System
Video
Audio
Network
Serial
Event
Preset
Record
User
Camera

Video

Apply

Encode

Input Format: Composite NTSC

Input deinterlace: Off On

Resolution: 720x480

Framerate: 30

Preference: Bitrate

Quality: Economy

Bitrate: 2000 kbps (32 ~ 8000)

I-Frame Interval: 100

H.264 Profile: High Profile

Dual Encode

Use Dual Encode: Off On

Dual Encode Algorithm: H.264 MJPEG

Resolution: 720x480

Framerate: 30

Preference: Bitrate

Quality: Economy

Bitrate: 1024 kbps (32 ~ 1024)

I-Frame Interval: 100

H.264 Profile: High Profile

Motion Detection

Use Motion Detection: Off On



Edit: Enable Disable

Mode: Set Erase

Apply Edited Area

Sensitivity(0 for most sensitive): 5

Information Display

SystemID: Off On

Time: Off On

Position: Bottom Top

BurnIn OSD

SystemID: Off On

Time: Off On

Position: Bottom Top

Font Size: Small (8x8) Middle (16x16) Large (32x32)

Color

Brightness: 50

Contrast: 50

Hue: 50

Saturation: 50

– ENCODE

■ Input Format

Select input format; Composite NTSC or PAL

■ Resolution

Selectable video compression resolution as below:

NTSC: 720 x 480, 720x 240, 352 x 480, 352 x 240

PAL: 720 x 576, 720 x 288, 352 x 576, 352 x 288

■ Frame Rate

Select video frame rate (the maximum number of frames of video images to compress).

The frame rate transmitted can be affected by the network bandwidth limitations.

■ Preference

Preference in video compression and transmission: With 'Bitrate' selected, the video compression will be effected by the 'Bitrate' value entered. With 'Quality' selected, the video compression will be effected by the quality of image selected. Therefore, 'Bitrate' and 'Quality' corresponds to CBR (Constant Bitrate) and VBR (Variable Bitrate) respectively.

■ Quality

VBR (Variable Bit Rate) adjusts the bit rate according to the image complexity, using up bandwidth for increased activity in the image and less for lower activity in the monitored area.

■ Bitrate

CBR (Constant Bit Rate) allows you to set a fixed target bit rate that consumes a predictable amount of bandwidth. As the bit rate would usually need to be increased for increased image activity (in this case it is constrained) the frame rate and image quality are affected negatively.

■ I-Frame Interval

Setting numbers of P frames to each I frame between 0 and 255.

There will be no P-frame if 0 is set.

– DUAL ENCODE

■ Use Dual Encode

Select On to use dual encode

■ Dual Encode Algorithm

H.264 and MJPEG can be selected for secondary streaming. Maximum resolution is 720 x 480 and there are 8 steps of resolution. If MJPEG is selected, Preference supports only Quality mode. Bitrate can be set from 32~1024kbps for Dual Encode.

– MOTION DETECTION



■ Use Motion Detection

Select Motion Detection function

■ Motion Detection Area Editing

Configure regions for motion detection. Regions of arbitrary shape can be configured by the following steps.

- ① Enable **Edit** item.
- ② Select editing Mode. **Set** is for including cells to motion detection region and **Erase** is for excluding.
- ③ Select cells using the left button of the mouse. Multiple cells can be selected conveniently by press and dragging.
- ④ Press **Apply Edited Area** button to save the editing.

■ Sensitivity

Sensitivity is a condition to trigger an event of motion detection. The value determines the sensitivity of the motion detection within a block: the smaller, the more sensitive.

It is selectable from from 0 to 10.

■ Information Display

System ID and/or server time can be displayed over the video window in Web View. Each item can be turn on or off and position can be configured as well. This information is displayed after the video is decompressed.

■ Burn-in OSD

Insert system ID and date/time in the compressed video. System ID and time respectively can be turned on or off in the video. And position and Font size can be selectable.

2.3 Audio Configuration

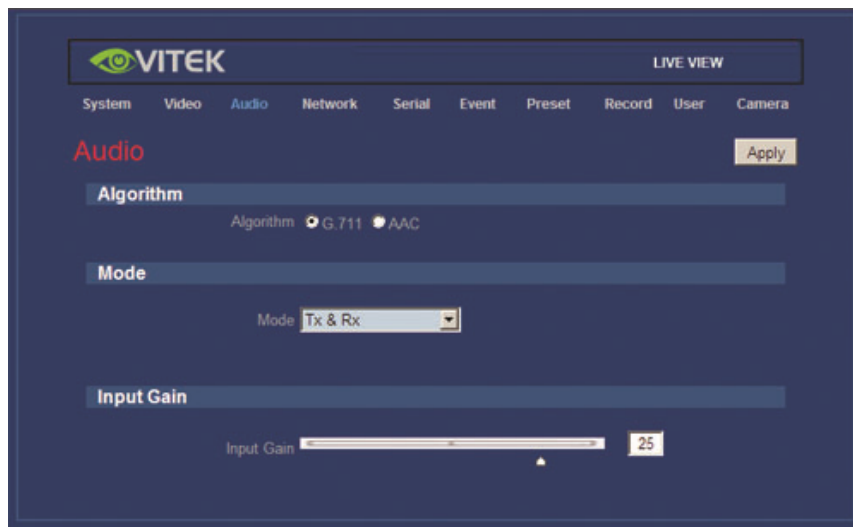

■ Algorithm

Algorithm: Select the audio algorithm: G.711 or AAC

Bit rate: Select the Bit rate between 64kbps and 128kbps when AAC is selected

The sampling rate is fixed to 32KHz when AAC is selected.

Note that when VT-IPSD102H is connected to a decoder, the decoder's audio algorithm should be set identically to transmit audio properly.

■ Mode

Select audio operation mode.

Mode	Status
Off	No operation
TX-Only	Transmit only
RX-Only	Receive only
TX & RX	Transmit and Receive

■ Input Gain

Set audio input gain.

2.4 Network Configuration

LIVE VIEW

System
Video
Audio
Network
Serial
Event
Preset
Record
User
Camera

Network Apply

Local

IP Mode: Fixed IP

Local IP: 192.168.10.100

Local Gateway: 192.168.10.1

Local Subnet: 255.255.255.0

DNS

Obtain DNS server address automatically
 Use the following DNS server addresses

Primary DNS Server: 0.0.0.0

Secondary DNS Server: 0.0.0.0

Port

Base Port: 2222

HTTP Port: 80

RTSP Port: 554

Discovery

UPNP: Off On

Zeroconf: Off On

Authentication

RTSP Authentication: Off On

HTTPAPI Authentication: Off On

RTP Session

Use RTP Session: Off On

Destination IP: 0.0.0.0

Destination Port: 0

User Name:

File Name: ch0.sdp

SNMP

SNMP Listen port: 161

SNMP Trap Destination IP: 0.0.0.0

SNMP Trap Destination Port: 162

Multicast

Multicast IP: 224.10.0.0

DDNS

DDNS Server: None TrueDNS DynDNS Vdyn

Check IP Disable

Bitrate Control

Flow Control Mode: Frame Drop Mode

Address Information

Current IP: 192.168.10.100

Current Domain: Not RegisteredB

MAC Address: 00:1C:63:AC:04:28

Connecting 1 :: 192.168.10.99 - (1,0)

■ IP Mode

Two IP modes are supported. Depending on the selected mode, further configuration items come as follows.

IP Mode	Selection	Description
Fixed IP	Local IP	Fixed IP address
	Local Gateway	Gateway IP address
	Local Subnet	Subnet mask
DHCP IP	N/A	

 Please, get IP address information from your ISP provider or network manager.

■ DNS

Set DNS server IP address.

■ Base Port

Network base port is used for communication between systems. In order for the VT-IPSD102H and remote systems to be connected together, each port number must be identically set.

■ HTTP Port

HTTP port used for web-based connection

■ RTSP Port

RTSP port used for RTSP-based connection

■ SNMP

VT-IPSD102H can be used as an SNMP agent. It is compatible to both SNMPv1 and SNMPv2c. Vender specific MIBs for IP camera/server are defined. SNMP listen port can be set and disabled when it is 0. SNMP trap is also supported. Destination IP and port can be set. If one of these values is 0, SNMP trap will be disabled.

■ Multicast IP

The multicast IP address selection range is between 224.0.1.0 and 238.255.255.255. The selection can be used only when media protocol is set to Multicast. The multicast address must be the same for the system to be connected using multicast protocol.

■ Address Information

Tree addresses are checked by 3 ways below. (Read-only)

IP Address

The servers own IP address. This information is useful when the server's IP mode is set to DHCP.

Domain Name

In case the server is registered with a DDNS server, the registered domain name is displayed.

MAC Address

Display the MAC address of the server. If the server is registered with DDNS server, the MAC address is used in DDNS registration.

2.5 Serial Port Configuration

The screenshot displays the VITEK web interface for Serial Port Configuration. The interface includes a navigation menu at the top with options: System, Video, Audio, Network, Serial, Event, Preset, Record, User, and Camera. The 'Serial' tab is selected, and an 'Apply' button is visible in the top right corner.

COM2 (RS-485 Port)

- Protocol: RS-485
- Bitrate: 2400bps
- Data Bit: 8Bits
- Parity: None
- Stop Bit: 1Bits

PTZ

- PTZ Type: Pelco-D
- PTZ ID: 1
- PTZ Port: COM2

Sensor Type

Sensor 1: Off N/O N/C

Sensor Schedule

Select: Sensor Off Sensor On

Sensor 1

	0	1	2	3	4	5	6	7	8	9	10	11	12	13	14	15	16	17	18	19	20	21	22	23
SUN																								
MON																								
TUE																								
WED																								
THU																								
FRI																								
SAT																								

■ Serial Port Configuration

There are two serial ports, (COM1 and COM2) in VT-IPSD102H. While COM1 port is fixed to RS-232C, COM2 port can be set to RS-422 or RS-485 protocol.

The serial ports can be configured as follows.

Mode	Selection
Bitrate	2400, 4800, 9600, 19200, 38400, 57600, 115200 bps
Data Bits	5, 6, 7, 8 bits
Parity	NONE, EVEN, ODD bit
Stop Bit	1, 2 bit

Each of the serial ports configurations must be same as connecting device.

■ PTZ Configuration

PTZ Type

Select the type of PTZ camera or receiver.

PTZ ID

Since it is possible to control multiple PTZ cameras or receivers over single control line, each camera or receiver will be assigned a unique ID. Enter PTZ ID of a camera or receiver for control. The ID value range can be between 0 and 255.

PTZ Port

Select the serial port used for PTZ camera control.

■ Sensor Type

There are two sensor input ports on VT-IPSD102H. Each of the sensor ports can be configured to the following.

Function	Operation
OFF	Not used
NO (Normally Open)	The port is normally open and activated when closed.
NC (Normally Closed)	The port is normally closed and activated when opened.

The function of the sensor port is set based on the type of the sensor connected.

■ Sensor Schedule

Each sensor port can be enabled or disabled in day (of a week) and hour unit. Sensor is disabled for grey-colored duration.

2.6 Event Configuration

LIVE VIEW

System
Video
Audio
Network
Serial
Event
Preset
Record
User
Camera

Event Apply

Local

Sensor Alarm E-mail FTP No Preset No Preset

On Video Loss Alarm E-mail FTP No Preset No Preset

On Motion Alarm E-mail FTP No Preset No Preset

Remote

Sensor1 Alarm E-mail FTP No Preset No Preset

Sensor2 Alarm E-mail FTP No Preset No Preset

Sensor3 Alarm E-mail FTP No Preset No Preset

Sensor4 Alarm E-mail FTP No Preset No Preset

On Disconnect

Duration

Alarm 1sec

E-mail Notification

Server Address

Port 25

Sender Address

Authentication on SMTP server Off On

ID

Password

Destination Address

Video Clip Attaching Off Primary Video Secondary Video JPEG Capture

Number of Frame 1 (1 ~ 10)

E-mail Test

Before testing e-mail, please apply your configuration first.

FTP Upload

Server Address

Port 21

ID

Password

FTP Base Directory

Upload Video Primary Video Secondary Video JPEG Capture

Number of Frame 1 (1 ~ 10)

Continuous Upload Off On

Upload Duration 10 sec (Max 300)

Upload Interval 300 sec (Max 3600)

FTP Test

Before testing FTP, please apply your configuration first.

Event Record

Pre-event Time None

Post-event Time None

The event configuration configures the actions for each event type. **Local** section configures the actions for events from local (self) system, and configuration activates local devices and a **Remote section configures** the actions for events from remote (peer) system.

The following table lists the possible actions for events.

Action	Description
Beep	Outputs beep sound using the buzzer in the system
Alarm1/Alarm2	Triggers alarm (relay) port
E-mail	Sends E-mail to the specified address. AVI file can be attached
FTP	Upload AVI file to a specified FTP server
Preset	Moves the PTZ to associated preset position

■ Sensor1 / Sensor2

Configure the actions when the sensor 1 or 2 is activated. Multiple actions can be set for a single event.

■ On Video Loss

Configure the actions when video input signal is lost. Multiple actions can be set for a single event.

■ On Motion

Configure the actions when motion is detected. Multiple actions can be set for a single event.

■ On Disconnect

Configure the actions when the link (connection) with peer system is disconnected. Multiple actions can be set for a single event.

■ Alarm and Beep activation duration

Set the duration of alarm or beep activation in case of an event. If it is set to continuous, it will be in active state until an operator reset it manually.

■ E-mail Notification

Specify the information to send E-mail as the action of an event. The address of mail (SMTP) server needs to be specified in the **Server Address** field, and **Port** specifies the port for SMTP operation (Port 25 is the default port in SMTP operation. If a different port is configured in the SMTP server, this port needs to be changed accordingly). When the server requires authentication, ID and password of an E-mail account need to be entered also. Destination address needs to be entered in the **Destination Address** field. More than one address can be entered by delimiting comma (,) or semi-colon (;). Destination address can take up to 63 characters. Video clip of AVI file format at the moment of the event can be attached by setting **Video Clip Attaching**.

■ FTP Upload

Specify the information for uploading video file as the action of an event. The address of an FTP server to receive video files is specified on **Server Address** field, and **Port** specifies the port for FTP operation (Port 21 is the default port in FTP operation. If different port is configured in the FTP server, this port needs to be changed accordingly). ID and password for accessing the FTP server also need to be specified. Video clip of AVI file format or JPEG file at the moment of the event can be attached by setting **Video Clip Attaching**.

By setting **Continuous Upload** to **On**, it is possible to upload video clips periodically regardless of events. **Upload Duration** specifies the duration of one upload file, and **Upload Interval** specifies how often it should happen. Upload Interval doesn't include the duration. If Upload Interval is 60 and Upload Duration is 20, it uploads a file for 20 seconds duration every 80 seconds.

■ Event Recording

Specify how a video clip is to be generated for E-mail sending or FTP uploading.

Pre-event Time specifies the duration of recording before an event happens. **Post-event Time** specifies the duration after the event is cleared.

2.7 Preset Configuration

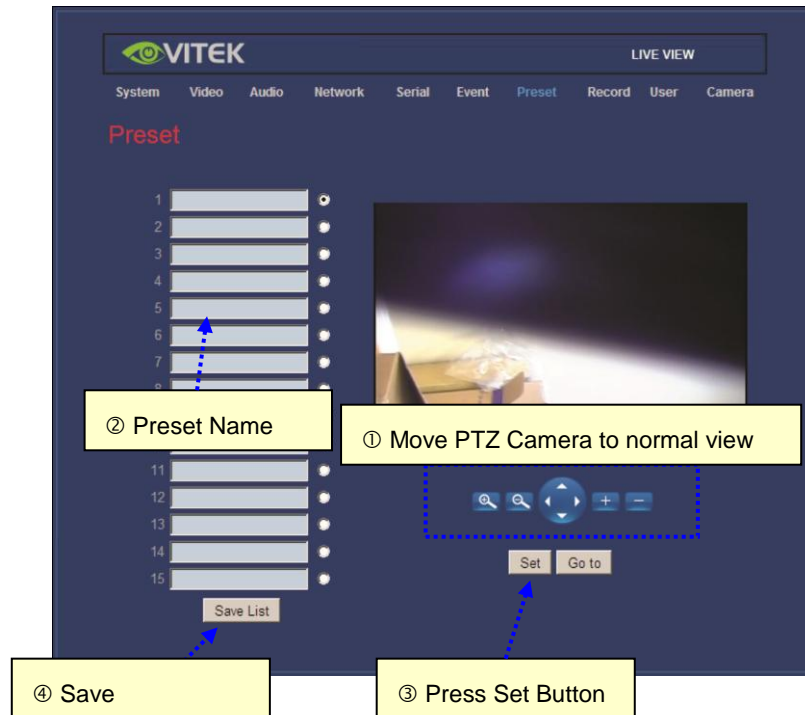

Configure up to 15 preset positions. Preset function is not available on some PTZ receivers. Make sure to check if a PTZ receiver supports preset.

■ Preset Configuration

Set the PTZ Presets by following the next steps.

- ① Move cameras to desired view using PTZ control buttons.
- ② Enter Preset name.
- ③ Press **Set** button.
- ④ Once all the presets are set, press **Save List** button.

■ Move to Preset Position

Select a preset from the Preset and press the **Go To** button. The camera will move to the selected preset position.

2.8 User Configuration

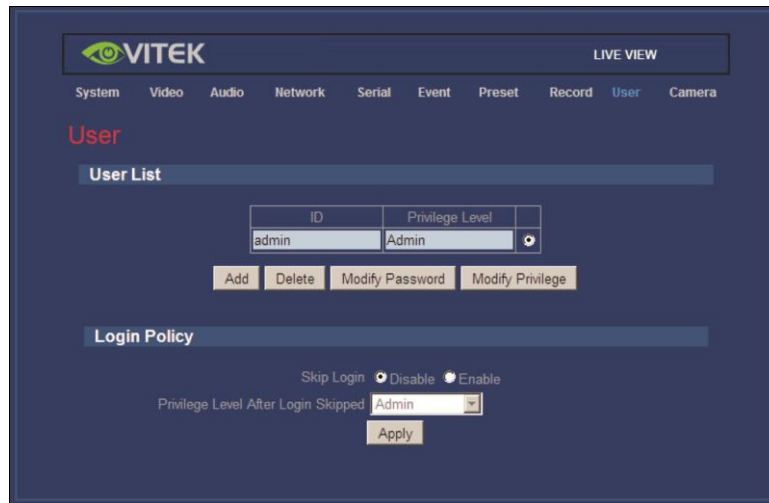

User can be registered and privilege level of a user can be specified. User configuration is allowed only to admin user. Max 16 users can be registered and each user can have one of four privileges.

Privilege	Allowed Operations	Remarks
Admin	All operations	User id = admin
Manager	All operations except for user configuration	
User	Live viewing and PTZ control	
Guest	Live viewing only	

■ Add User

Page for adding a user comes on pressing **Add** button.

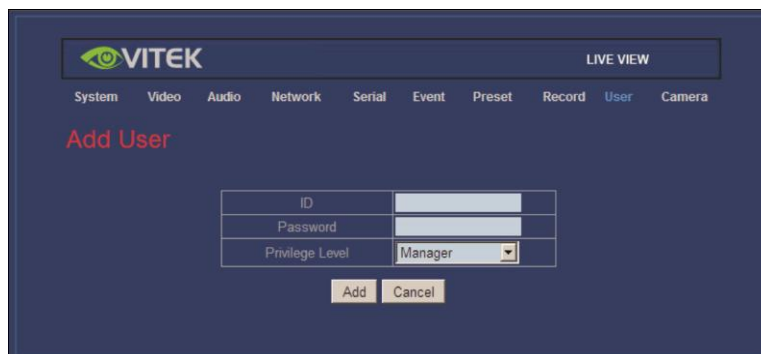

User ID and password need to be entered and privilege level needs to be selected. User ID and password consist of an alphanumeric string of max 15 characters.

■ Delete User

A user is deleted by pressing **Delete** button.

Change Password

Pressing the **Modify Password** button after selecting a user shows a page for changing password.

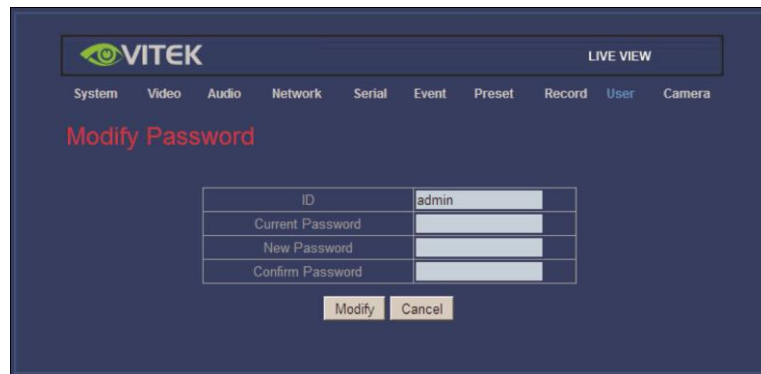

If changing the admin password, the old password is checked first.

■ Modify Privilege Level

Pressing the **Modify Privilege** button after selecting a user shows a page for changing the privilege. It is not allowed to change the privilege level of admin user.

■ Login Policy

Skip Login is provided for convenient access to the server when authentication is not required. When **Skip Login** is set to Enable, login step is skipped. The privilege level after logging in this way is determined by the setting of **Privilege Level After Login Skipped**.

3. Decoder System

The screenshot displays the VITEK web interface for system configuration. At the top, there is a navigation menu with options: System, Video, Audio, Network, Serial, Event, Preset, Record, User, and Camera. The 'System' tab is selected. Below the navigation, the 'System' section is highlighted in red. The 'General' section contains input fields for 'System ID', 'BurnIn OSD System ID' (with a note '(alphanumeric characters only)'), and a dropdown for 'Language' set to 'English'. An 'Apply' button is located below these fields. The 'Firmware' section shows 'Version' as 'Enc.V1.103C-001' and 'Board ID' as '63'. It includes an 'Upgrade' button, a 'Browse...' button, and a 'Firmware Upgrade' button. The 'Time' section features 'Start Time' (2011/05/27 6:10:16), 'Current Time' (2011/05/27 7:27:05) with a 'Set Current Time' button, 'Time Format' (YYYY/MM/DD hh:mm:ss), 'Time Zone' ((GMT-12:00) International Date Line West), and a checkbox for 'Automatically synchronize with NTP server'. The 'NTP Server Name' is set to 'pool.ntp.org'. An 'Apply' button is at the bottom of this section. The 'Reboot' section has a 'Reboot' button, and the 'Factory Reset' section has a 'Factory Reset' button.

Once system mode is changed as decoder, Firmware version shows Dec xxxxxxxx which means decoder mode.

3.1 Video Configuration

Regardless of the input resolution of the Encoder or IP camera, Decoder system of VT-IPSD102H can display video format as follows;

- Composite NTSC & HDMI 480i (720 x 480)
- Composite PAL & HDMI 576i (720 x 576)
- HDMI & HD-SDI 720p60 (1280x720)
- HDMI & HD-SDI 1080p60 (1920 x 1080)
- HDMI & HD-SDI 720p50 (1280 x 720)
- HDMI & HD-SDI 1080i50 (1920 x 1080)

3.2 Network Configuration

Network page of Decoder has a section for specifying the remote system to connect.

The screenshot displays the VITEK Network Configuration interface. At the top, there is a navigation menu with options: System, Video, Audio, Network (selected), Serial, Event, Preset, Record, User, and Camera. The 'LIVE VIEW' button is visible in the top right corner. The main heading is 'Network' with an 'Apply' button to its right. The configuration is organized into several sections:

- Local:** IP Mode is set to 'Fixed IP'. Local IP is 192.168.10.100, Local Gateway is 192.168.10.1, and Local Subnet is 255.255.255.0.
- DNS:** The option 'Obtain DNS server address automatically' is selected. Primary and Secondary DNS Servers are both set to 0.0.0.0.
- Port:** Base Port is 2222, HTTP Port is 80, and RTSP Port is 554.
- Discovery:** UPNP and Zeroconf are both set to 'Off'.
- Authentication:** RTSP Authentication and HTTPAPI Authentication are both set to 'Off'.
- RTP Session:** 'Use RTP Session' is set to 'Off'. Destination IP is 0.0.0.0, Destination Port is 0, User Name is empty, and File Name is 'ch0.sdp'.
- SNMP:** SNMP Listen port is 161, SNMP Trap Destination IP is 0.0.0.0, and SNMP Trap Destination Port is 162.
- Multicast:** Multicast IP is 224.10.0.0.
- DDNS:** DDNS Server is set to 'None'. There is a 'Check IP Disable' checkbox.
- Bitrate Control:** Flow Control Mode is set to 'Frame Drop Mode'.
- Address Information:** Current IP is 192.168.10.100, Current Domain is 'Not RegisteredB', MAC Address is 00:1C:63:AC:04:28, and Connecting 1 is 192.168.10.99 - (1,0).

- Remote Address

Address of the remote system to connect.

- Remote Channel

The channel can be selected when the remote system has more than one video channels.

- Media Protocol

Protocol used for delivery of audio and video data between remote system and Decoder.

- Use Streaming Server

Decoder system has the settings to connect to the Encoder or IP Camera via the Streaming Server. To connect to the Encoder or IP Camera via Streaming Server, **Use Streaming Server** in the **Remote** group on the **Network** page should be set to **On**. Information for the **Streaming Server (SS)** needs to be configured appropriately.

3.3 Event Configuration

Event Apply

Local

Sensor Alarm E-mail FTP No Preset

On Video Loss Alarm E-mail FTP No Preset

On Motion Alarm E-mail FTP No Preset

Remote

Sensor1 Alarm E-mail FTP No Preset

Sensor2 Alarm E-mail FTP No Preset

Sensor3 Alarm E-mail FTP No Preset

Sensor4 Alarm E-mail FTP No Preset

On Disconnect

Duration

Alarm

E-mail Notification

Server Address

Port

Sender Address

Authentication on SMTP server Off On

ID

Password

Destination Address

Video Clip Attaching Off Primary Video Secondary Video JPEG Capture

Number of Frame (1 ~ 10)

Before testing e-mail, please apply your configuration first.

FTP Upload

Server Address

Port

ID

Password

FTP Base Directory

Upload Video Primary Video Secondary Video JPEG Capture

Number of Frame (1 ~ 10)

Continuous Upload Off On

Upload Duration sec (Max 300)

Upload Interval sec (Max 3600)

Before testing FTP, please apply your configuration first.

Event Record

Pre-event Time

Post-event Time

The event configuration configures the actions for each event type. The **Local** section configures the actions for local events (self=Decoder) system, and configuration activates local devices and **Remote** sections configures the actions for events from remote (Encoder or IP Camera) system.

The following table lists the possible actions for events.

Action	Description
Beep	Outputs beep sound using the buzzer in the system
Alarm1/Alarm2	Triggers alarm (relay) port
E-mail	Sends E-mail to the specified address. AVI file can be attached
FTP	Upload AVI file to a specified FTP server
Preset	Moves the PTZ to associated preset position

■ Sensor1 / Sensor2

Configure the actions when the sensor 1 or 2 is activated. Multiple actions can be set for a single event.

■ On Video Loss

Configure the actions when video input signal is lost. Multiple actions can be set for a single event.

■ On Motion

Configure the actions when motion is detected. Multiple actions can be set for a single event.

■ On Disconnect

Configure the actions when the link (connection) with peer system is disconnected. Multiple actions can be set for a single event.

■ Alarm and Beep activation duration

Set the duration of alarm or beep activation in case of an event. If it is set to continuous, it will be in active state until an operator resets it manually.

5. ENVI Visual Management Software (VMS)

1. ENVI Visual Management Software

ENVI VMS is a program used for basic configuration, diagnostics and F/W upgrades of video servers or IP cameras. **ENVI VMS** provides the following features:

- Finding servers on the LAN and assigning IP address
- Monitoring server status: encoding/decoding, serial, sensor etc.
- Diagnostic function: PING, network bandwidth measurement, video/audio output port check, serial port check
- F/W upgrade

2. Server Registration and Removal

■ Server Registration

In order to manage servers using ENVI VMS, the first step is to register the server.

- ① Select **Add Server** on **Server** menu.

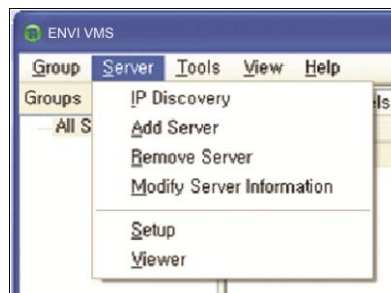

- ② Enter information for connecting to the server at **Add Server** dialog.

A screenshot of the 'Add Server' dialog box. It contains the following fields: Server Name (Main Gate), Address (192.168.10.133), Port (2222), HTTP Port (80), ID (admin), and Password (masked with dots). There are 'Add' and 'Cancel' buttons at the bottom.

If the server is registered on DDNS server, the domain name can be used instead of an IP address. When the IP address of the server is forgotten, it is possible to find the IP address of the server with IP Discovery function. (Please refer to IP Discovery section).

③ Press **Add** button.

■ **Removal of a server**

A server can be removed with the following steps:

- ① Select the server to remove on **Servers** tab; the selected server is highlighted in blue.
- ② Select **Remove Server** on the **Server** menu.

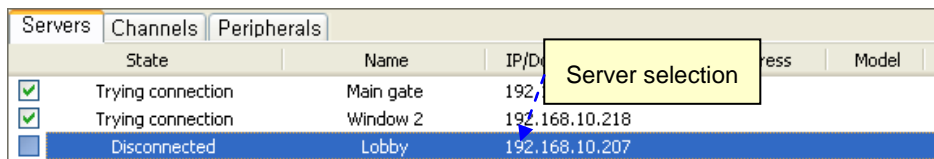

■ **Modification of information for a server**

Information for a server can be modified on the dialog invoked by selecting **Modify Server Info** on the **Server** menu.

■ **IP Discovery**

Using the IP Discovery function, all the servers on the same LAN where the PC executing the ENVI VMS is located can be found. Furthermore, it is possible to change the IP address of a server easily. **IP Discovery** dialog is invoked by pressing the **IP Discovery** button on **Add Server** dialog, and it shows all systems on the same LAN.

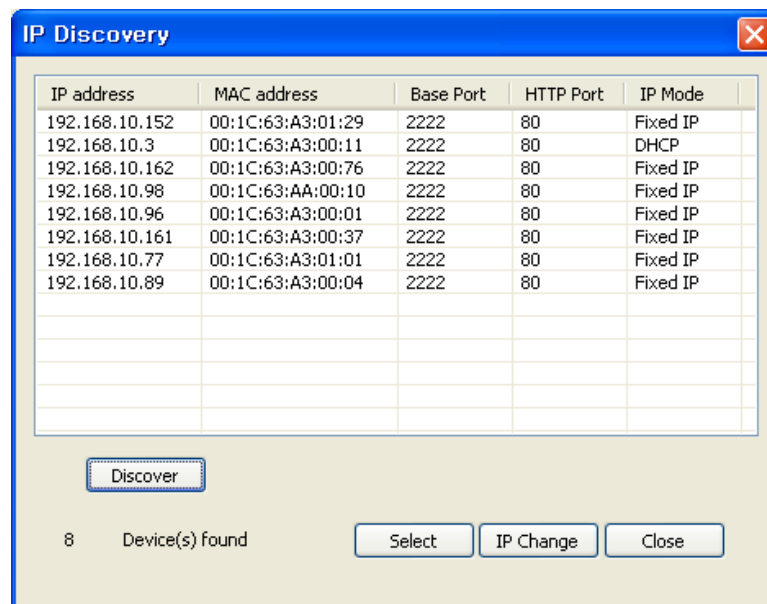

If you press the **Select** button after selecting a server, the information for the server is automatically entered in the **Add Server** dialog box. Pressing the **IP Change** button after selecting a server invokes

a dialog box where the IP address of the server can be changed.

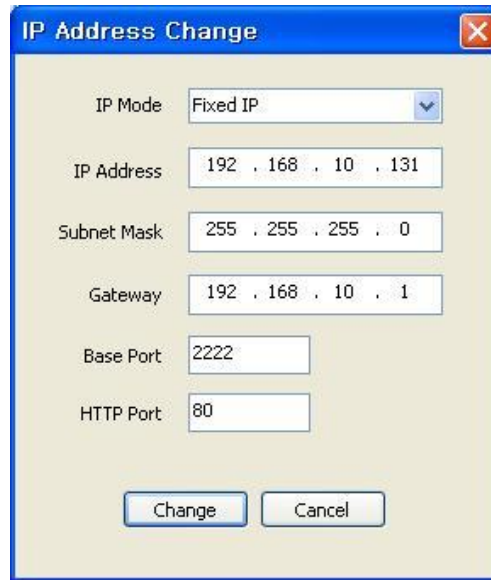

It is possible to change the IP address of a server which has an IP address of a different subnet.

■ **Grouping of servers**

When there are a large number of servers, it is convenient to manage servers in several groups. Server groups can be created and deleted by using **Add Group** and **Remove Group** on the **Group** menu. The **Modify Group** menu is used to add servers to a group or to remove servers from a group.

3. Server Connection Management

■ **Server connection**

If the box is checked in the first column in the **Servers** (or **Channels/Peripheral**) tab, the ENVI VMS will try to connect to the server. If the server is running and the network to the server is normal, it will be connected immediately and **State** will be changed to **Connected**.

Servers							
State	Name	IP/Domain Name	MAC Address	Model	Type	Firmware	Start Up Time
<input checked="" type="checkbox"/>	Connected	3	192.168.10.3	00:1C:63:A3:00:11	TCS-200	Encoder	Encoder:V1.TEST 2007/08/11 15:15:53
<input type="checkbox"/>	Disconnected	Main gate	192.168.10.4				
<input checked="" type="checkbox"/>	Connected	Ware house	192.168.10.161	00:1C:63:A3:00:37	TCS-200	Encoder	Encoder:V1.101G 2007/08/08 19:57:56

Check box to connect or disconnect server

If it fails to connect to the server due to server or network failure, State displays **Trying connection**. As soon as the server or network is recovered, it will be connected automatically. ENVI VMS periodically retries the connection to servers when the check box is checked.

■ **Server disconnection**

If the check box is unchecked, the connection to the server is released and **State** displays **Disconnected**.

4. Server Status Monitoring

■ Servers tab – General information

Servers tab shows general information for a connected server: MAC address, product model, system mode (Type) F/W version and startup time. This information comes only for connected servers.

Servers Channels Peripherals								
State	Name	IP/Domain Name	MAC Address	Model	Type	Firmware	Start Up Time	
<input checked="" type="checkbox"/>	Connected	3	192.168.10.3	00:1C:63:A3:00:11	TCS-200	Encoder	Encoder:V1.TEST	2007/08/11 15:15:53
<input checked="" type="checkbox"/>	Connected	Main gate	192.168.10.96	00:1C:63:A3:00:01	TCS-200	Encoder	Encoder:V1.TEST	2007/08/11 09:18:55
<input checked="" type="checkbox"/>	Connected	Ware house	192.168.10.161	00:1C:63:A3:00:37	TCS-200	Encoder	Encoder:V1.101G	2007/08/08 19:57:56

■ Channels tab - Monitoring of video/audio channel state

The **Channels** tab displays how the video and audio channels of the servers are working.

Servers Channels Peripherals												
State	Server Name	Ch	Conns	Cam	Motion	V-E (kbps)	V-E (fps)	V-D (kbps)	V-D (fps)	A-E (kbps)	A-D (kbps)	
<input checked="" type="checkbox"/>	Connected	3	1	2	OK	1090	33	0	0	68	76	
<input checked="" type="checkbox"/>	Connected	Main gate	1	2	OK	1797	30	0	0	0	0	
<input checked="" type="checkbox"/>	Connected	Ware house	1	1	OK	970	30	0	0	62	0	

Item	Displays
Ch	Channel no.
Conns	Number of clients connected to a server (including ENVI VMS)
Cam	Video loss status
Motion	Motion status
V-E(kbps)	Video encoding bitrate
V-E(fps)	Video encoding framerate
V-D(kbps)	Video decoding bitrate
V-D(fps)	Video decoding framerate
A-E(kbps)	Audio encoding bitrate
A-D(kbps)	Audio decoding bitrate

Depending on the system mode, items that are not relevant to the mode may display 0. For example, V-D(kbps) and V-D(fps) are always 0, if the system mode is Encoder.

■ Peripherals tab – Monitoring of serial, sensor and relay port

Peripherals tab displays the status of serial, sensor and relay ports.

Servers Channels Peripherals										
State	Server Name	COM1-TX	COM1-RX	COM2-TX	COM2-RX	Sensor1	Sensor2	Buzzer	Relay1	Relay2
<input checked="" type="checkbox"/>	Connected	3	0	0	0	0	Off	Off	Off	Off
<input checked="" type="checkbox"/>	Connected	Main gate	0	0	0	0	Off	Off	Off	Off
<input checked="" type="checkbox"/>	Connected	Ware house	0	0	0	0	Off	Off	Off	Off

Item	Displays
COM1-TX COM1-RX	Activity of RS-232C port - TX: server -> external equipment - RX: external equipment -> server
COM2-TX COM2-RX	Activity of RS-422/485 port - TX: server -> external equipment - RX: external equipment -> server
Sensor1 Sensor2	States of sensor ports
Buzzer	State of buzzer
Relay1 Relay2	States of relay ports

5. Network and System Diagnostics

ENVI VMS provides various diagnostic features with which the reason for the following situations can be found.

- Connection between two systems or between the system and VMS (Video Management System) is not established.
- Video, audio or serial data are not delivered as configured.
- Video and/or audio outputs don't come on output port.

■ Ping test

Ping Test dialog can be invoked by selecting **Ping Test** on the **Tools** menu after selecting a server.

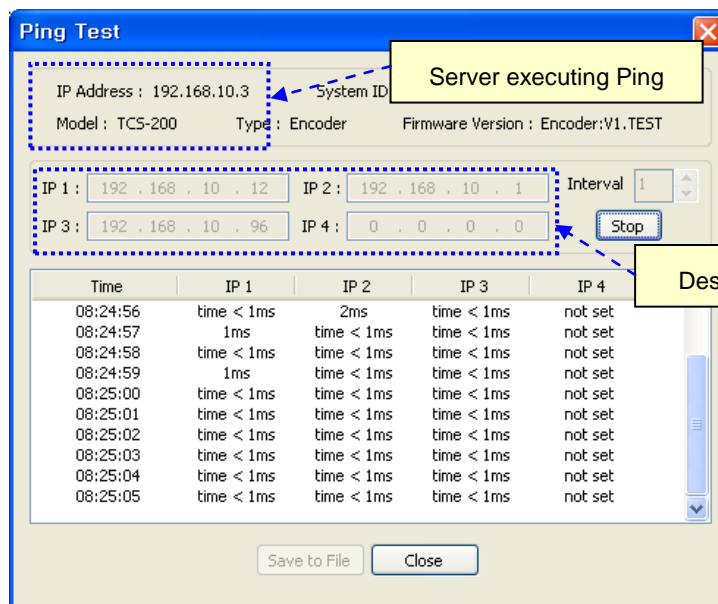

Ping test is useful for checking if one or more remote systems are reachable from a server. Up to 4 systems can be registered as the targets of a Ping test, which makes it possible to identify the hop (segment of network) where network failure may happen. For example, local router, remote router and remote Encoder can be pinged from a Decoder simultaneously.

■ **Network test**

Network Test dialog is invoked by selecting **Network Test** on the **Tools** menu.

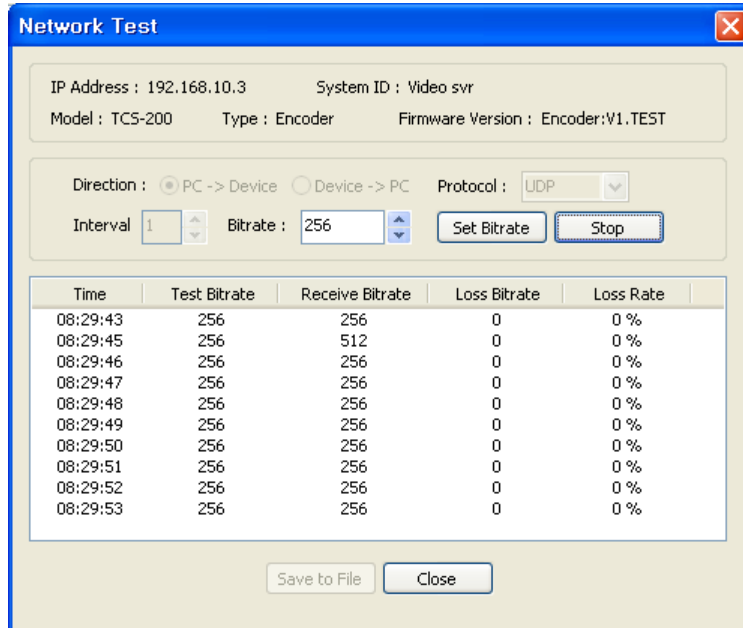

Network test can be used for measuring effective bandwidth and/or packet loss rates between a server and a PC running the ENVI VMS by generating test traffic of constant bitrate. This feature is useful for identifying the reason why video quality comes poorer than expected. TCP protocol can be selected for measuring effective bandwidth, while UDP protocol is appropriate for checking if the network is not reliable.

■ **System test**

Selecting System Test on the Tools menu invokes a dialog box on which system H/W status, video/audio output function and serial ports can be diagnosed.

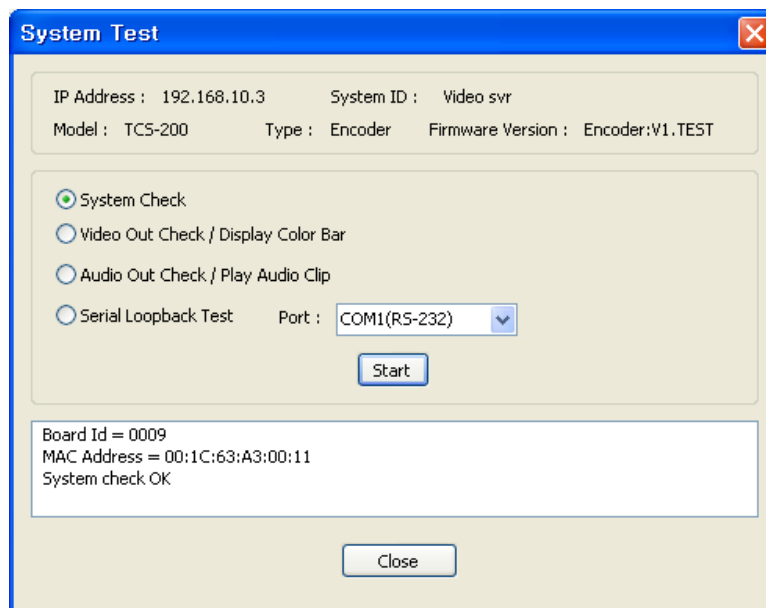

System Check

System Check tests if H/W components are fine and displays board ID and MAC address.

Video Out Check / Display Color Bar

It displays color bar on video output port. This function works for Decoder or Duplex mode, and is useful for checking if video output port or external display device is normal.

Audio Out Check / Play Audio Clip

It plays audio clip and outputs to audio output port. This function is useful for checking if the audio output function of a server or external audio output devices such as amplifier and speaker are normal.

Serial Loopback Test

Using this function, it is possible to check if a serial port is alive. When this function is started after forming the loopback in a serial port (i.e. connecting pin 2 and 3 together in case of RS-232C port), numbers of bytes sent and received are displayed. The port is normal if number of sent bytes and number of received bytes are equal.

■ Viewing server's log

Select **Log** in the **Tools** menu to view a server.

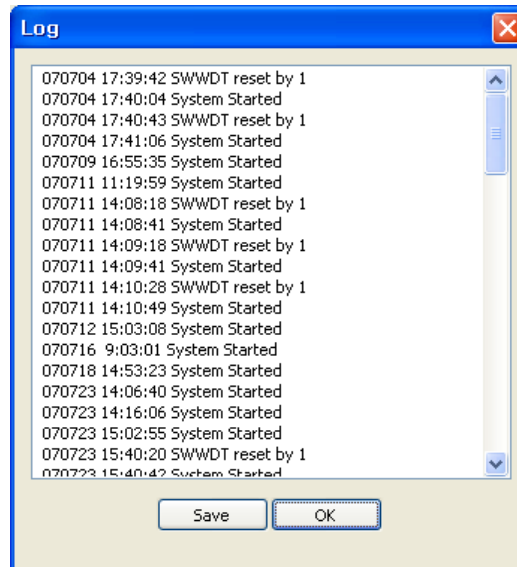

■ Remote rebooting of a server

A server can be rebooted by selecting **Reboot** in the **Tools** menu.

6. F/W Upgrade

When **Update** is selected on the **Tools** menu, the dialog for F/W upgrade appears.

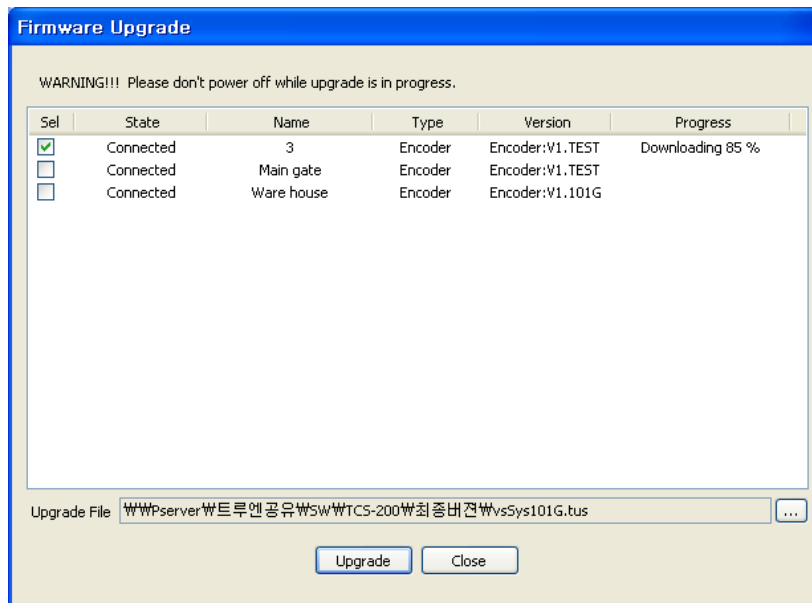

- ① Select a server to upgrade (check the check box in **Sel** column). More than one server can be upgraded simultaneously.
- ② Select an upgrade file.
- ③ Press **Upgrade** button.
- ④ Wait until **Progress** is changed to **Upgrade succeeded**.

Caution: Don't power-off the server while upgrade is in progress. The server may go to irrecoverable state.

When the network condition is poor, the upgrade may fail. In such case, please reattempt the procedure above after the network condition is recovered.

7. Remove Configuration and Video Monitoring

Video servers and IP cameras provide web-based Setup and video viewing. If **Setup** on **Server** menu is selected, Internet Explorer is invoked and the page for remote setup of the server is displayed. If **Viewer** is selected on the menu, Internet Explorer displays the video from the server.

6. Trouble Shooting

1. Illegal Connect Error

If an unauthorized connection has been established, the system will not function properly. Maintaining the connection, an error condition will be displayed requesting correction.

An illegal connect sign will appear in conditions such as:

- 1) Incompatible Media protocol between two systems
- 2) Other unauthorized connections

Even if illegal connect condition occurs, normal operation between systems with authorized connections will not be effected. The color of link LED will change to orange and it blinks.

Appendix A: Sensor and Alarm Port

1. Sensor Port

■ Terminal Type

- * Voltage Rating: 150VAC
- * Current Rating: 2A
- * Color: Red

■ Sensor Signal Input Type

- * NO Contact Signals

■ Connection to External Device

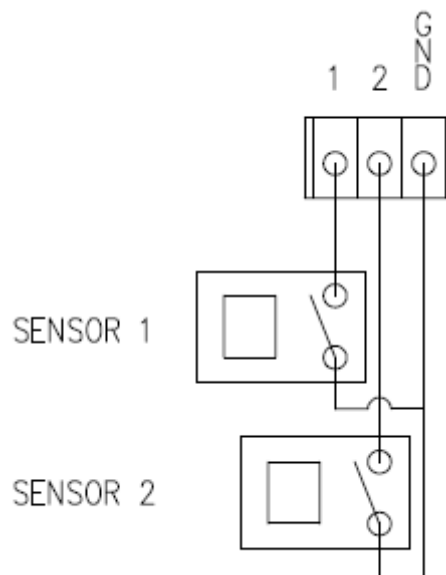

2. Alarm Port

■ Terminal Type

- * Voltage Rating: 150VAC
- * Current Rating: 2A

■ Relay Type

- * Contact Rating: 1A 30VDC
- * Switching Power: Max 30W 62.5VA
- * Switching Voltage: Max 60VDC

■ Alarm Signal Output Type

- * NO/NC Contact Signals

■ Connection to External Device

Appendix B: Serial Port

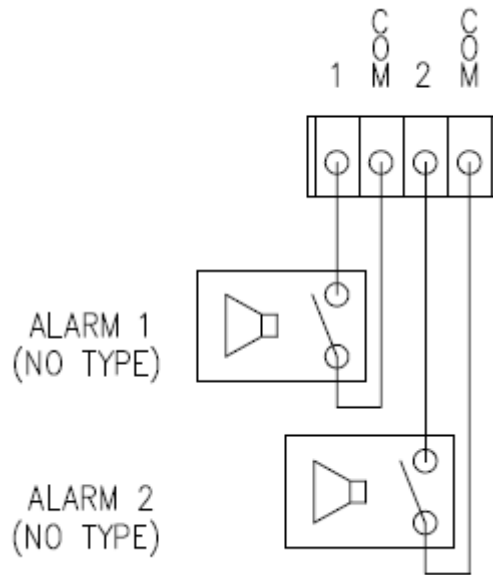

1. RS-232 Port

■ Port Type

* 3 PIN

* Pin Arrangement

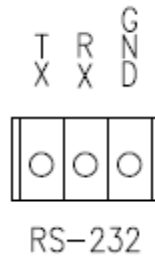

* Pin Description

Pin NO	Pin Name	Description
1	TX	RS232 TX (Transmit)
2	RX	RS232 RX (Receive)
3	GND	Ground

2. RS-422/485 Port

■ Port Type

* 4 PIN

* Pin Diagram

RS-422/485 TERMINALS



* Pin Description

Pin No.	Pin Name	Description
1	RX-	RS422 RX-
2	RX+	RS422 RX+
3	TX-	RS422 TX- or RS485 TRX- It is selectable by S/W Setup
4	TX+	RS422 TX+ or RS485 TRX+ It is selectable by S/W Setup

VITEK LIMITED PRODUCT WARRANTY

VITEK products carry a three (3) year limited warranty. VITEK warrants to the purchaser that products manufactured by VITEK are free of any rightful claim of infringement or the like, and when used in the manner intended, will be free of defects in materials and workmanship for a period of three (3) years, or as otherwise stated above, from the date of purchase by the end user. This warranty is non-transferable and extends only to the original buyer or end user customer of a VITEK Authorized Reseller.

The product must have been used only for its intended purpose, and not been subjected to damage by misuse, willful or accidental damage, caused by excessive voltage or lightning.

The product must not have been tampered with in any way or the guarantee will be considered null and void.

This guarantee does not affect your statutory rights.

Contact your local VITEK Reseller should servicing become necessary.

VITEK makes no warranty or guarantee whatsoever with respect to products sold or purchased through unauthorized sales channels. Warranty support is available only if product is purchased through a VITEK Authorized Reseller.



28492 CONSTELLATION ROAD VALENCIA, CA 91355
WWW.VITEKCCTV.COM | 888-VITEK-70